

SUMMARY

Des femmes, des hommes, des régions, **nos ressources...**



QUÉBEC'S FOREST RESOURCES AND INDUSTRY
A STATISTICAL REPORT 2010 ÉDITION

Québec 

SUMMARY

QUÉBEC'S FOREST
RESOURCES AND
INDUSTRY

A STATISTICAL REPORT
2010 EDITION

DESIGN, RESEARCH AND TEXT

Blaise Parent, F.E.

Ministère des Ressources naturelles et de la Faune

Direction du développement de l'industrie

des produits forestiers

880, chemin Sainte-Foy, bureau 7.50

Québec, Québec G1S 4X4

CANADA

Telephone: (418) 627-8644, ext. 4112

Fax: (418) 643-9534

Note:

The preparation of this report required the collaboration of all the administrative units within the Secteur des forêts and Forêt Québec. Unless otherwise indicated, the data are provided by the administrative unit of the ministère des Ressources naturelles et de la Faune with responsibility for the sector in question.

© Gouvernement du Québec

Ministère des Ressources naturelles et de la Faune, 2010

ISSN on line 1499-9080

ISBN 978-2-550-58457-5 (PDF)

FOREWORD

In keeping with its mission, the ministère des Ressources naturelles et de la Faune (MRNF) continues to make different tools available to anyone interested in the forests, including this document. As in past years, the 2010 edition of **Québec's Forest Resources and Industry** contains a **succinct statistical report** on Québec's forest sector. However, this year we have made some minor changes to the content. For example, the survey chapter data are drawn exclusively from the third ten-year forest survey.

The full version of **Québec's Forest Resources and Industry** is available in French only, in **PDF** and **Excel** formats on the MRNF's website at : <http://www.mrnfp.gouv.qc.ca/forets/connaissances/connaissances-statistiques.jsp>¹. To facilitate research, French-language and English-language summaries, containing the highlights of each chapter along with the principal maps and tables, are also available on the same website.

We hope you find this year's report as useful as past editions and, as always, we welcome your comments.

1. The full version is updated regularly, and we invite you to obtain the most recent data by consulting it on a regular basis.

NOTE TO READERS

The full version of this document (in French only) can be obtained from the website of the Ministère des Ressources naturelles et de la Faune (<http://www.mrnfp.gouv.qc.ca/>) by clicking on the **Forêts, Connaissances forestières et environnementales** and **Les Statistiques forestières** tabs, and then selecting **complète** or **résumée**. In the Excel version, the tabs appearing at the bottom of the screen provide access to the various sheets.

Readers wishing to use the data contained in this publication should bear in mind the changes made to some of the tables illustrating statistical trends. An attempt to compare this year's tables with those of previous years may be difficult and lead only to confusion. In the Excel version, some data may appear to be cut off, due to on-screen column widths. To remedy this problem, use the PDF version or simply print the file instead of consulting it on screen.

For further information, please contact the author, Blaise Parent, at (418) 627-8644, extension 4112.

IMPORTANT NOTES

Each table, chart and map has been assigned a reference code, which is indicated in the upper right-hand corner. The first two figures of the code correspond to the chapter, the next two to the section and the last two to illustration. For example, code **02.01.03** designates the third illustration of the first section of chapter 2.

The letter (g) added in parentheses at the end of the code 05.01.10 (g) signifies that this page contains the source data for the graphic 05.01.10. As well, the number (2) added in parentheses at the end of the code 12.01.01 (2) indicates that this page contains the data from the preceding table, 12.01.01, including data on the furniture and/or printing industry.

Symbols Used in the Tables and Diagrams

.. : data not available
... : data not shown
p : provisional data
r : revised data
e : estimated data
x : confidential data
- : none or zero
— : small cap data

Symbols used

TSMAs : Timber supply and forest management agreements
FMAs : Forest management agreements
FMCs : Forest management contracts
cm : centimetre
cm³ : cubic centimetre
SIC : Standard Industrial Classification for companies and industries (1980 structure) Statistics Canada
dm³ : cubic decimetre
€ : euro
G : \$, billion
ha : hectare
hl : hectolitre
k : \$, thousand
kg : kilogram
km : kilometre
km² : square kilometre
L : litre
lb : pound
m : metre
m² : square metre
m³ : cubic metre
M : \$, million
Kbd ft : thousand, board feet
Mbd ft : million, board feet
Gbd ft : billion, board feet
no. : number
n.e.s. : not elsewhere specified
sq.ft. : square foot
bd ft : board foot
" : inch
NAICS : North American Industry Classification System (Statistics Canada's new 2000 structure)
FSPL : fir, spruce, jack pine, larch
t : ton
mt : metric ton
BDMT : bone-dry metric ton
ngrv : nominal gross raw volume
% : percent
\$: dollar
£ : pound sterling
¥ : yen

Conversion factors

1 cord of wood = 85 solid cubic feet = 2.41 cubic metres
1 cunit = 100 solid cubic feet = 2.831 cubic metres
1 board foot (bd ft) = a piece of wood 1 inch thick by 1 foot wide by 1 foot long
1,000 board feet (bd ft) = 2.36 cubic metres (net value)
1 cubic metre = 423.7 bd ft = 35.3 cubic feet = 0.353 cunits = 1.5 stacked cubic metres
1 metric ton (long ton) = 1,000 kilograms = 2,205 pounds
1 imperial ton (short ton) = 2,000 pounds
1 square kilometre = 100 hectares = 0.386 square miles
1 hectare = 2.47 acres

GLOSSARY OF THE MAIN ECONOMIC TERMS USED IN THE TEXT

Establishment

The smallest operating unit, generally a mill or factory, able to provide data on its inputs, outputs and activities for calculation of added value.

Total jobs

Positions related to production or to non-manufacturing activities in an establishment (cafeteria, head office, administration or sales). Also includes jobs generated by new construction, repairs or major alterations. Ownership and active partnership positions, which are not considered as salaried positions, are not included in the total jobs figure.

Total salaries and wages

Amounts allocated for compensation of all the salaried and non-salaried employees of an organization.

Value of shipments and other income

Value of shipments of company-specific products plus income obtained from non-manufacturing activities such as the sale of goods purchased and resold without processing, the book value of construction and capital work carried out by the establishment's personnel, for its own use, the cafeteria, etc.

Value added to total activity

Value added in the manufacturing activity, plus added value from non-manufacturing activities. This latter figure is obtained by subtracting from gross non-manufacturing production all purchases of goods for resale without processing (taking into account the net stocks variable for those goods), purchases of materials and supplies used in new construction or the production of machinery and tools for use by the establishment, and office supplies purchased and used by the establishment in a non-manufacturing activity.

Capital Expenditures

Capital expenditures include the cost of acquiring, constructing and installing plant, materials and sustainable tools, whether for replacement or rental.

Maintenance and repairs

Amounts paid to maintain works, materials and tools in good condition. They are not considered to be capital expenditures and are indicated separately.

GLOSSARY OF THE MAIN ECONOMIC TERMS USED IN THE TEXT (cont'd)

Constant dollars

Dollars in a reference year used as a basis for converting dollars from other years, to eliminate the impact of fluctuations in purchasing power. The conversion is made using a price index.

Balance of trade

The difference between the monetary value of exports and imports of merchandise, goods and services. If a country exports more than it imports, its balance of trade is positive. If it imports more than it exports, its balance of trade is negative.

National exports

Products grown, extracted or manufactured in Canada and sold to other countries, including products from foreign sources that are processed in Canada.

Shipment

Shipment of merchandise (goods) to a domestic or foreign destination.

Imports

All merchandise introduced into a country, whether for immediate consumption or storage.

Selling price index

An index showing variations in the general rate of inflation or price variations in a given economic sector, compared with a reference year to which a value of 100 is assigned.

Gross domestic product (GDP)

The value of all final goods and services produced in a given period within the geographical boundaries of a country or territory.

Summary

Total area of Québec¹: 1,667,441 km²

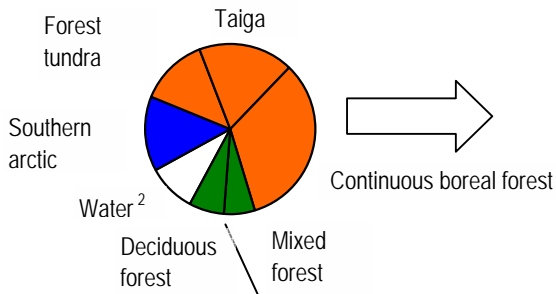

Vegetation zones and subzones ³		1,514,100 km ²
(according to the 1998 ecological classification)		
• Arctic	• • Southern arctic	236,000 km ²
• Boreal	• • Forest tundra	217,100 km ²
	• • Taiga	299,900 km ²
	• • Continuous boreal forest	551,400 km ²
• Northern Temperate	• • Mixed forest	98,600 km ²
	• • Deciduous forest	111,100 km ²

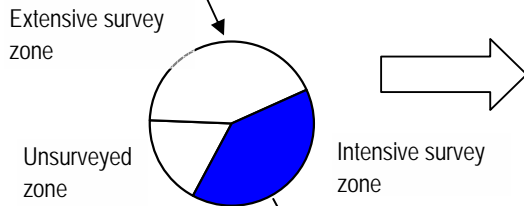

Land area ⁴		1,497,753 km ²
• Unsurveyed zone		267,322 km ²
• Extensive survey zone		638,882 km ²
• Intensive survey zone		591,549 km ²

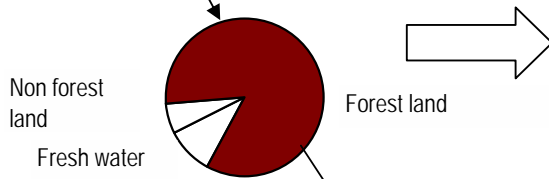

Intensive survey zone ⁵		591,549 km ²
• Fresh water	(-) 58,302 km ²	
• Non-forest land	(-) 34,894 km ²	
• Forest land		498,353 km ²

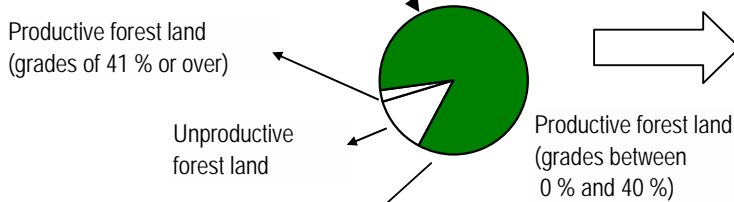

Forest land		498,353 km ²
Unproductive forest land	(-) 62,838 km ²	
Productive forest land		435,515 km ²
• Grades of 41% or over	(-) 11,401 km ²	
• Grades between 0% and 40%		424,114 km ²

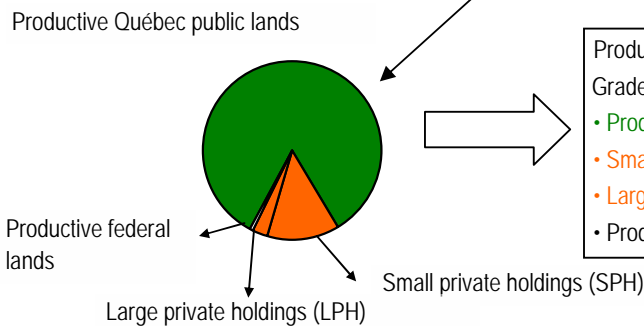

Productive forest lands		424,114 km ²
Grades between 0% and 40%		424,114 km ²
• Productive Québec public lands		355,004 km ²
• Small private holdings (SPH)		55,306 km ²
• Large private holdings (LPH)		10,940 km ²
• Productive federal lands		2,864 km ²

Merchantable volume		3,791,919 218 m ³
		3,124,028,567 m ³
		546,006,000 m ³
		91,471,900 m ³
		30,412,700 m ³

- Area obtained from a compilation of Québec border data to a scale 1:20,000, calculated using the Modified Transverse Mercator (MTM) system and the NAD83 geodesic reference system. Excludes Labrador, in accordance with the 1927 (non-definitive) boundary.
- Includes the waters of the St. Lawrence River downstream of the eastern point of Orleans Island, the Gulf of St. Lawrence up to the 1964 boundary with the Maritime provinces; also includes James Bay, Hudson Bay, Ungava Bay and Hudson Strait (153,341 km²).
- The limits of the bioclimatic domains have been revised by the Comité sur la carte des régions écologiques. The committee also established the new ecological land classification system in 1998 (includes inland waters but excludes the waters of the St. Lawrence River downstream of the eastern point of Orleans Island). The figures have been rounded off, possibly creating minor errors in the totals.
- Updated September 2004 : The original territorial data are drawn from the third ten-year forest survey (except the Magdalen Islands, for which data are drawn from the second forest survey). This area also includes inland waters but excludes the waters of the St. Lawrence River.
- Lands whose forests can be developed over 120 years, in keeping with the principle of sustained yield.

Summary (cont'd)

Distribution of productive Québec public lands

Areas covered by TSFMAs

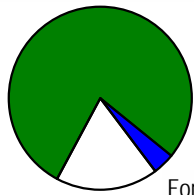

Areas covered by FMCs

Forest reserves free of rights

Productive Québec public lands

(grades between 0 % and 40 %)

- Areas covered by timber supply and forest management agreements (TSFMAs) and forest management agreements (FMAs) (March 31, 2009)

- Areas covered by forest management contracts (FMCs) (March 31, 2009)

- Forest reserves free of rights and areas where forest production is prohibited (RSFM¹, parks, etc.)

355,004 km²

276,968 km²

13,736 km²

64,300 km²

Surface areas taken into account in calculating the allowable annual cut (March 31, 2009)

Areas covered by TSFMAs

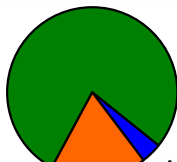

Areas covered by FMCs

Private lands

Québec public lands on which rights have been granted

- TSFMAs and FMAs²
- FMCs

Productive private lands taken into account in calculating allowable annual cut

(grades between 0 % and 40 %)

SPH² : 55,306 km², LPH² : 10,940 km²

276,968 km²

13,736 km²

66,246 km²

Allowable annual cut (March 31, 2009)

Allowable annual cut in public forests

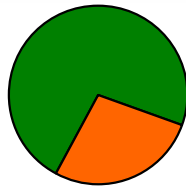

Allowable annual cut in private forests

Allowable annual cut - Québec public forests (common areas)

- Fir, spruce, jack pine, larch
- Other softwoods
- Poplars
- Other hardwoods

44,165,250 m³

32,196,500 m³

21,773,700 m³

820,300 m³

2,930,900 m³

6,671,600 m³

Allowable annual cut - private forests (large and small private holdings)³

- Fir, spruce, jack pine, larch
- Other softwoods
- Poplars
- Other hardwoods

11,968,750 m³

4,639,650 m³

917,300 m³

2,311,600 m³

4,100,200 m³

Volumes allocated by TSFMAs and FMAs in public forests (March 31, 2009)

27,951,800 m³

- Fir, spruce, jack pine, larch
- Other softwoods
- Poplars
- Other hardwoods

21,474,800 m³

491,650 m³

1,971,000 m³

4,014,350 m³

1. RSFM : Regulation respecting standards of forest management for forests in the domain of the State.

2. SPH : Small private holdings.

LPH : Large private holdings.

3. Current volumes not included.

Summary (cont'd)

Volumes allocated by FMCs in public forests (March 31, 2009)

	845,328 m ³
• Fir, spruce, jack pine, larch	524,290 m ³
• Other softwoods	25,848 m ³
• Poplars	198,539 m ³
• Other hardwoods	96,651 m ³

Timber harvested - volume (2008-2009)

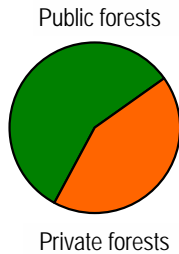

	23,354,500m ³
Public forests	17,236,900 m³
• Fir, spruce, jack pine, larch	13,857,200 m ³
• Other softwood	168,400 m ³
• Poplars	1,155,800 m ³
• Other hardwoods	2,055,500 m ³
Private forests ¹	6,177,600 m³
• Fir, spruce, jack pine, larch	2,122,400 m ³
• Other softwood	196,000 m ³
• Poplars	1,008,200 m ³
• Other hardwood	2,791,000 m ³

1. Estimates.

Public forests (allowable annual cut, volume allocated, volume harvested) (2008)

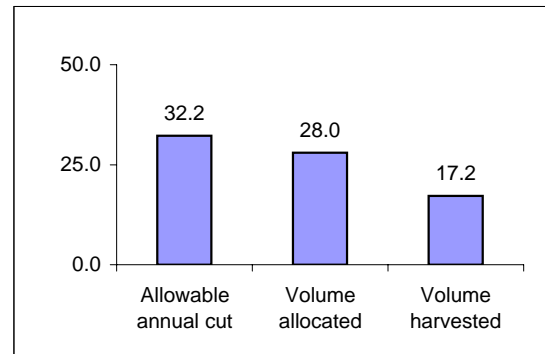

Private forests (allowable annual cut, volume harvested) (2008)

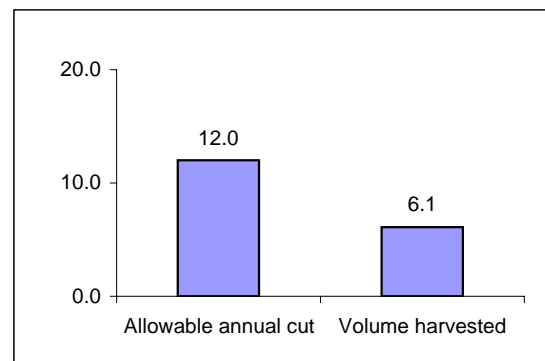

Summary (cont'd)

Forest protection

	2005	2006	2007	2008	2009
Area affected (ha)	823,401	186,848	453,426	135,086	415,114
Spruce budworm	43,270	50,500	110,743	133,603	321,146
Forest fires					
Intensive protection zone	366,671	13,768	278,033	133	17,948
Limited forest protection	413,460	122,580	64,650	1,350	76,020

Silvicultural treatments planned and carried out

	2007-2008	2008-2009	2007-2008r	2008-2009p
	Planned (ha)	Planned (ha)	Carried out (ha)	Carried out (ha)
Public forests	670,905	540,632	396,774r	354,146p
Site preparation	59,021	53,202	70,747r	73,774p
Planting and seeding	49,192	38,753	70,121r (112 M seedlings)	65,776p (144 M seedlings)
Non-commercial treatments	167,137	124,455	84,657r	73,909p
Commercial treatments	395,555	324,222	171,249r	140,687p
Private forests	67,430	67,430	49,372p	46,493p
Site preparation	7,605p	6,916p
Planting and seeding	12,591	12,591	8,574p (19 M seedlings)	8,284p (18 M seedlings)
Non-commercial treatments	7,618	7,618	18,663p	19,087p
Commercial treatments	47,221	47,221	14,530p	12,206p

Network of permanent roads (2005-2006e)

Total length : 16,700 km (590 bridges)

Experimental, teaching and research forests (2009)

Total area : 62,806 ha

From forest to mill ¹

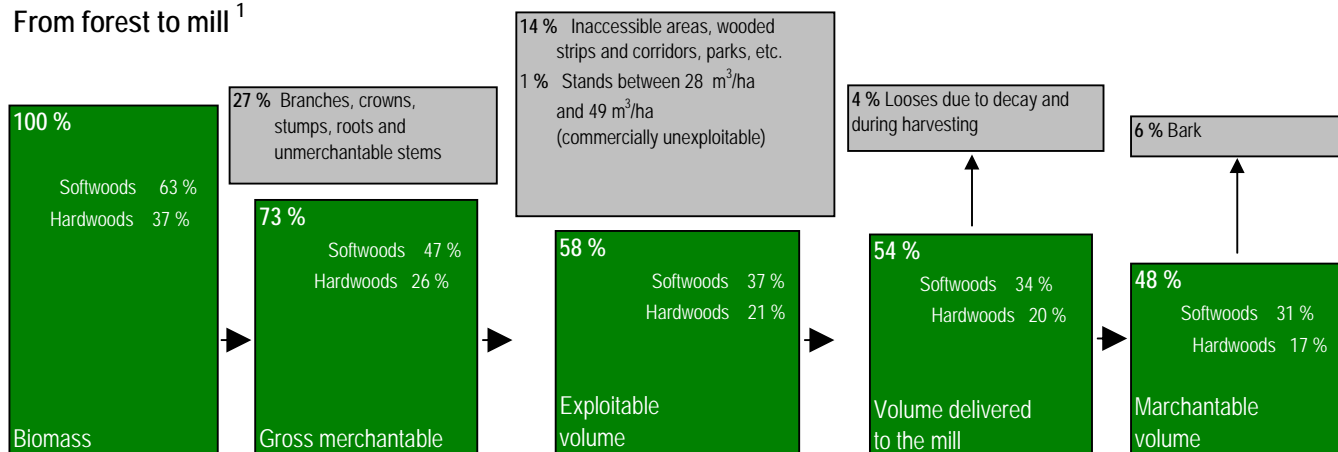

1 : Updated March 31, 2009.

Timber consumption by primary processing plants

	2007	2008
Total Consumption (m³)	58,648,627	51,812,987
Consumption by Species (m ³)		
Fir, spruce, jack pine, larch	44,653,127	39,915,774
Other softwoods	1,678,332	1,498,335
Poplars	4,750,561	3,491,104
Other hardwoods	7,566,607	6,907,774
Consumption by Product (m ³)		
Roundwood	35,177,766	30,442,422
Chips	15,676,331	14,907,806
Sawdust, shavings and wood residues	7,794,530	6,462,759
Consumption by Source (m ³)		
Public forests	23,471,454	21,273,432
Private forests	6,206,997	4,732,130
Exchanges between mills	20,920,626	18,512,042
Outside Québec	8,049,550	7,295,383

Summary (cont'd)

The forest sector in Québec's economy (2007)

	Total jobs (no.)	Total salaries and wages (\$, 000s)	Value of shipments and other revenue (\$, 000s)	Value added to total activity ¹ (\$, 000s)	Capital expenditures and repairs (\$, 000s)
Forestry and logging (NAICS 113)	12,037	474,734	3,020,490	1,093,621	142,100
Wood product manufacturing (NAICS 321)	31,740	1,276,843	7,946,008	2,952,631	699,300
Paper manufacturing (NAICS 322)	23,571	1,389,101	10,138,535	3,796,211	690,800
Total (forest sector)	67,348	3,140,678	21,105,033	7,842,463	1,532,200

1. Including purchase of services.

Logging industry (2008)

Number of primary processing plants, including 321 sawmills	404
Number of pulp, paper and paperboard mills, 30 of which are included under primary processing plants	57

Wood processing industry establishments by group (2007)

Wood product manufacturing (NAICS 321)	1,577
Paper manufacturing (NAICS 322)	308
Total	1,885

Forest product production

	2007	2008
Lumber (m ³ , 000s)	14,588	12,368
Joint sawmill production (BDMT, 000s)	9,258	8,363
Chips	5,559	5,282
Sawdust and shavings	1,578	1,309
Bark	2,121	1,772
Pulp and paper production (BDMT, 000s)	9,355	8,635
Newsprint	3,071	3,036
Paperboard and paper other than newsprint	5,104	4,604
Market pulp	1,180	995e

Québec's balance of trade ¹ in the forest products sector (\$, million) ²

	2006	2007	2008
Wood, charcoal and wooden products	2,659	1,960	1,274
Pulp, paper and paperboard	6,314	5,532	5,841
Total	8,972	7,491	7,115

1. Balance of trade of commercial goods with international destinations.

2. Product designation according to the World Custom Organization's harmonized Commodity Description and Coding System.

Integration of the forest products industry

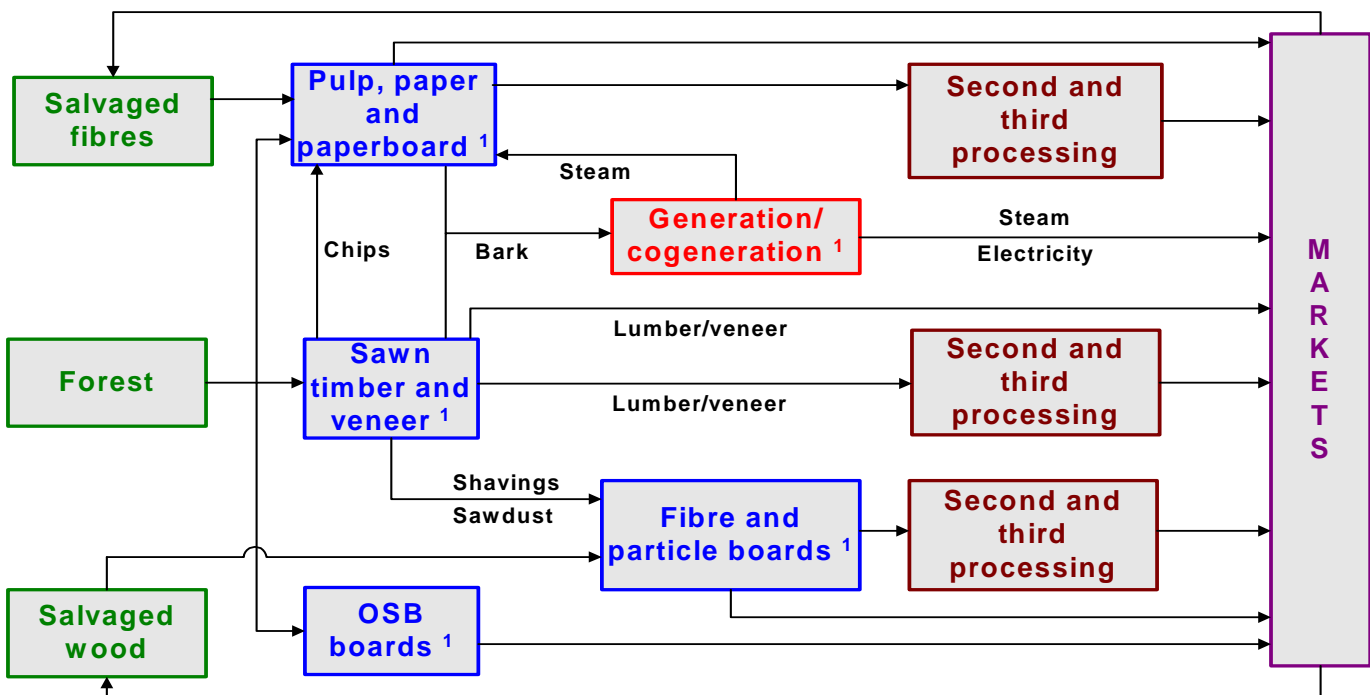

1. Primary processing.

Summary (cont'd)

The forest sector in Québec's economy (2007) (including furnitures and printing)

	Total jobs (no.)	Total salaries and wages (\$, 000s)	Value of shipments and other revenue (\$, 000s)	Value added to total activity ¹ (\$, 000s)	Capital expenditures and repairs (\$, 000s)
Forestry and logging (NAICS 113)	12,037	474,734	3,020,490	1,093,621	142,100
Wood product manufacturing (NAICS 321)	31,740	1,276,843	7,946,008	2,952,631	699,300
Furniture and related product manufacturing (NAICS 337)	30,712	998,422	3,906,318	2,133,587	134,000
Paper manufacturing (NAICS 322)	23,571	1,389,101	10,138,535	3,796,211	690,800
Printing and related support activities (NAICS 323)	18,885	835,106	3,332,805	1,915,812	179,100
Total (forest sector)	116,945	4,974,206	28,344,156	11,891,862	1,845,300
Overall manufacturing activity in Québec	451,724	20,736,263	156,321,340	66,779,941	62,534,300

1. Including purchase of services.

Logging industry (2008)

Number of primary processing plants, including 321 sawmills	404
Number of pulp, paper and paperboard mills, 30 of which are included under primary processing plants	57

Wood processing industry establishments by group (2007) (including furnitures and printing)

Wood product manufacturing (NAICS 321)	1,577
Furniture and related product manufacturing (NAICS 337)	2,800
Paper manufacturing (NAICS 322)	308
Printing and related support activities (NAICS 323)	1834

Forest product production (including furniture and printing)

	2007	2008
Lumber (m ³ , 000s)	14,588	12,368
Joint sawmill production (BDMT, 000s)	9,258	8,363
Chips	5,559	5,282
Sawdust and shavings	1,578	1,309
Bark	2,121	1,772
Pulp and paper production (BDMT, 000s)	9,355	8,635
Newsprint	3,071	3,036
Paperboard and paper other than newsprint	5,104	4,604
Market pulp	1,180	995e
Furniture and related product production (\$, 000s)	3,906	..
Printing and related support activities industry production (\$, 000s)	3,333	..

Québec's balance of trade¹ in the forest products sector (including furniture and printing) (\$, million)²

	2006	2007	2008
Wood product, furniture and related product manufacturing	3,538	2,446	1,439
Pulp and paper, paper and paperboard, converted paper product manufacturing and printing and related support activities mills	6,654	5,820	6,108
Total (forest products sector)	10,192	8,266	7,547

1. Balance of trade of commercial goods with international destinations.

2. According to the North American Industry Classification System (NAICS).

Integration of the forest products industry

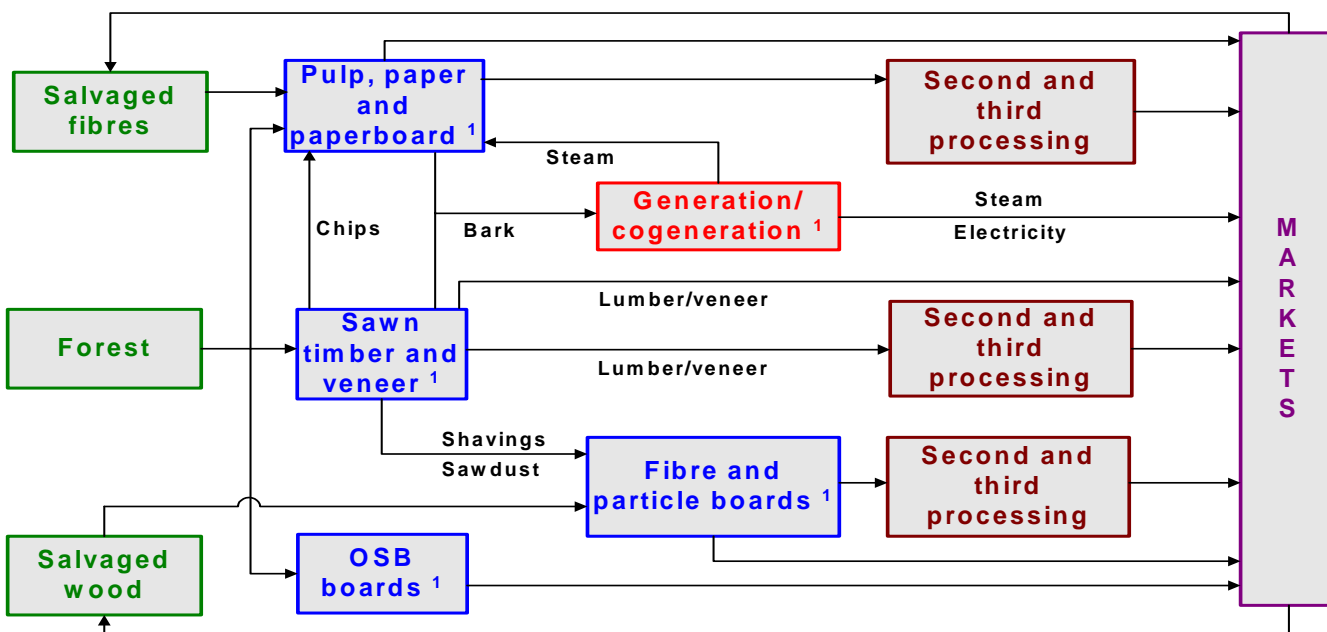

1. Primary processing.

Supplies for Québec's primary wood processing industry in 2008

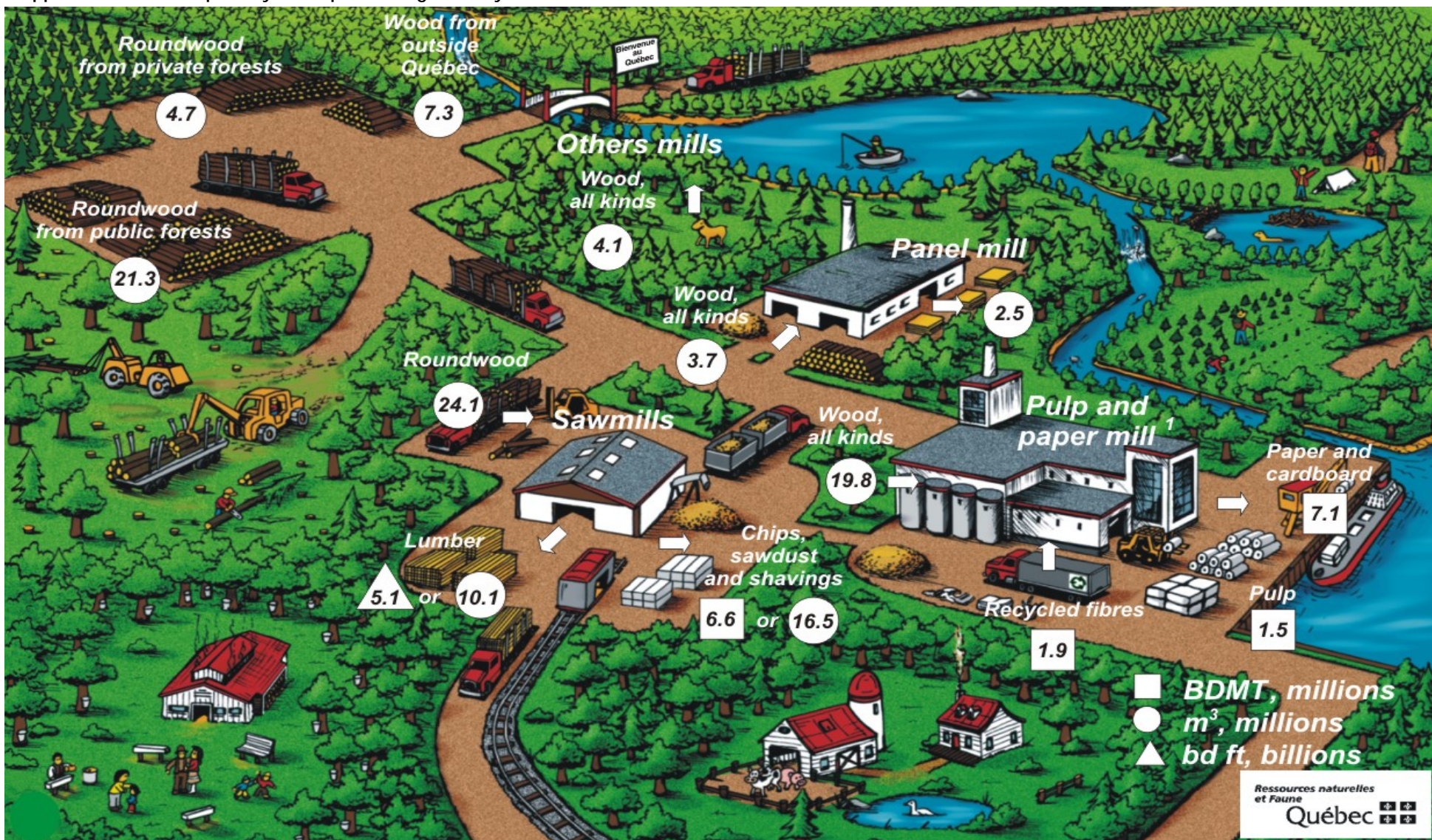

1. Including data from the 2008 annual survey.

Supplies for Québec's primary wood processing industry in 2008

Supplies by source (m³, million)

Public forests	21.3
Private forests	4.7
Outside Québec	7.3
Total	33.3

Mills consumption (m³, million)

Panel	3.7
Sawmills	24.1
Pulp and paper	19.8
Other mills	4.1
Total	51.7

Recycled fibres consumption (BDMT, million)¹

Pulp and paper	1.9
----------------	-----

Sawmills Production

Chips, sawdust and shavings	6.6 (BDMT, million)
	16.5 (m3, million)
Lumber	5.1 (bd ft, billion)
	10.1 (m3, million)

Pulp and paper mill production (BDMT, million)¹

Paper and paperboard	7.1
Market pulp	1.5

Panel mills production (m³, million)

Panel	2.5
-------	-----

1. Including data from the 2008 annual survey.

QUÉBEC'S FOREST RESOURCES AND INDUSTRY

TABLE OF CONTENTS

- Foreword
- Note to readers and important notes
- Symbols used in the Tables and Diagrams,
symbols used and conversion factors
- Glossary of main economic terms
- Summary
- Québec's primary wood processing
industry supplies
- 1. **Geographical distribution of Québec's forests**
Highlights
Vegetation zones and subzones
Public land use planning
Administrative divisions in Québec's public forests
Types of ownership and survey zones
Private forests
- 2. **Intensive survey zone**
Highlights
Area of productive forests (grades between 0 % and 40 %
and available gross merchantable volume
- 3. **Forest protection**
Highlights
Insects and diseases
Forest fires
- 4. **Sustainable development of Québec's forests**
Highlights
- 5. **Forest management**
Highlights
Allowable annual cut
Harvest
Forest dues
Seedling production
Summary of silvicultural treatments carried out
- 6. **Forest use for educational, recreational purposes,
research and experimental**
Highlights
- 7. **Non-timber Use**
Non-timber forest products (NTFPs)
Highlights
- 8. **Logging**
Highlights
- 9. **Timber use**
Highlights
Trade with markets outside Québec
in 2007 and 2008
- 10. **Wood industries**
Highlights
Overview
The sawmill industry
- 11. **The pulp and paper industry**
Highlights
Production capacity
Production
Environment
- 12. **The forest sector in Québec's economy**
Highlights
Economic and financial indicators

1 Geographical distribution of Québec's forests

Highlights

01.00.01

Total area of Québec	(km ²)
Total area	1,667,441 r
Land area ¹	1,497,753
Vegetation zones (according to the 1998 ecological classification) ² :	
• Arctic	236,000 r
• Boréal	1,068,400 r
• Northern temperate	209,700 r

Types of ownership	(km ²)
Public lands (Québec)	1,372,021
Private lands	116,398
Federal lands	9,334

1. Updated in September 2004 : The original territorial data are drawn from the third ten-year forest survey (except for the Magdalen Islands data, which are still drawn from the second survey)
This area also includes inland waters but excludes the waters of the St. Lawrence River
2. The bioclimatic domain boundaries have been reviewed by the Comité sur la carte des régions écologiques, which also established the new ecological classification system in 1998 (including inland water but excluding the waters of the St. Lawrence River downstream of the eastern point of the Orleans island)

Public land use planning	(km ²)
Public lands ¹	1,373,490
• Forest production prohibited	65,552
• Forest production allowed	86,830
• Forest production has priority :	367,856
- Forest and leisure area	6,650
- Forest production area	361,206
• Other resource production ²	853,252

1. The areas were established from data gathered in 1997, and differ slightly from the areas measured during forest surveys. In particular, they have not been adjusted to reflect the latest modifications, including those resulting from sales of land, for example. Harmonization should be completed shortly
2. Area with mining sites, energy development sites, etc., north of the common area boundary.

Survey zones	(km ²)
Intensive survey zone	591,549
Extensive survey zone	638,882
Unsurveyed zone	267,322

Administration of public forests, March 31, 2009

	(no.)
Administrative régions	17
Management units	74
Timber supply and forest management agreements (TSFMAs)	179
Forest management agreements (FMAs)	8
Forest management contracts (FMCs)	89

Management of private forests, 2007 and 2008

Development agencies (no.)	17
• Productive area (ha, 000s)	6,625
• Number of owners	129,850
• Number of owners in activity	74,015
Syndicates of wood marketing boards (no.)	15

Forest cooperatives, 2006-2007

Forest cooperatives (no.)	37
Members (no.)	3,411
Workers (4 weeks or over)	4,496
Silvicultural work (ha, 000s)	68,925
Harvest (m ³ , 000s)	3,320
Turnover (\$, millions)	224

1 Geographical distribution of Québec's forest Vegetation zones and subzones

01.01.01

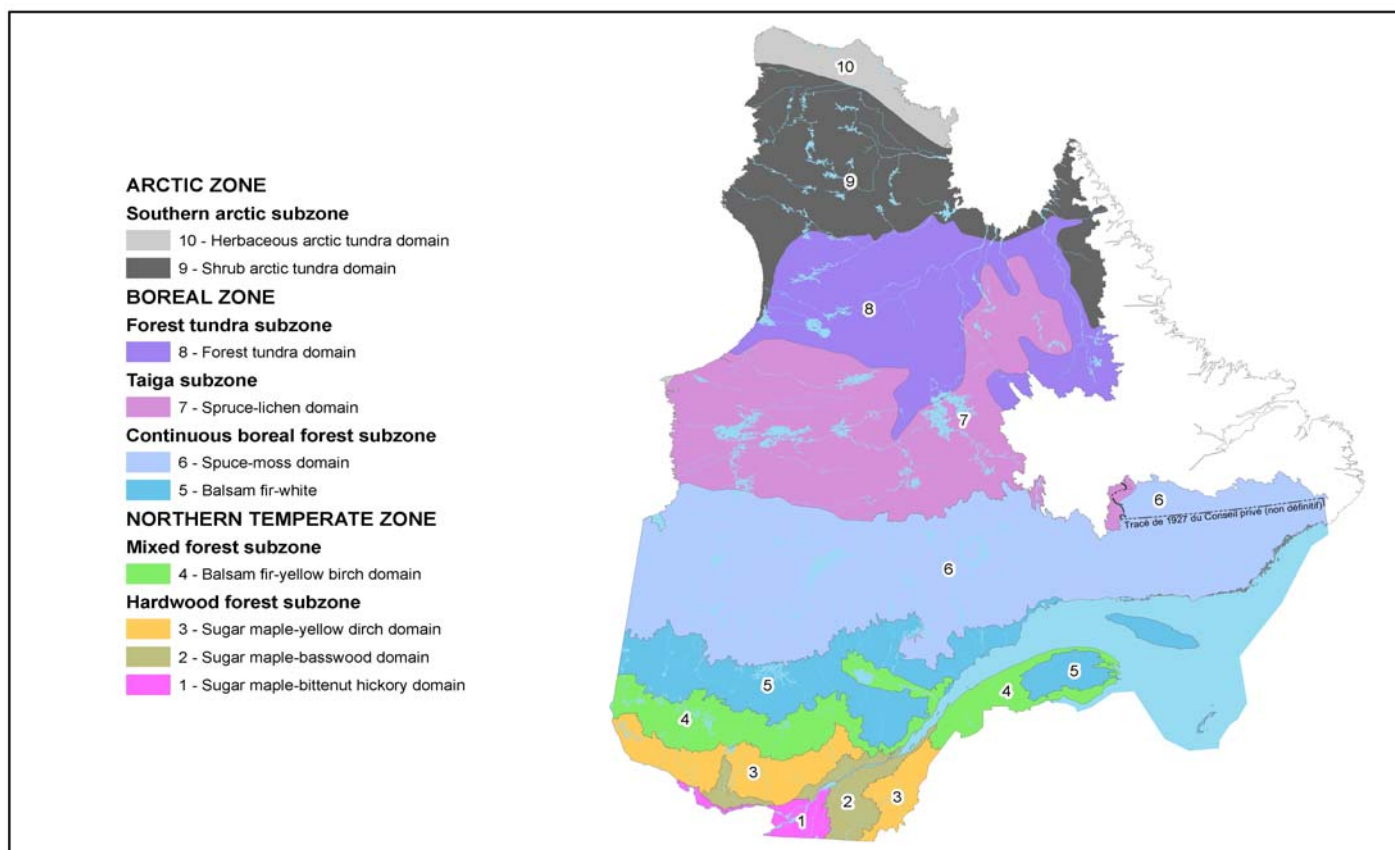

Source : Direction des inventaires forestiers, division écologie - productivité.

1 Geographical distribution of Québec's forests

Public land use planning

Areas subject to the land use planning process ^{1,2}

01.03.01

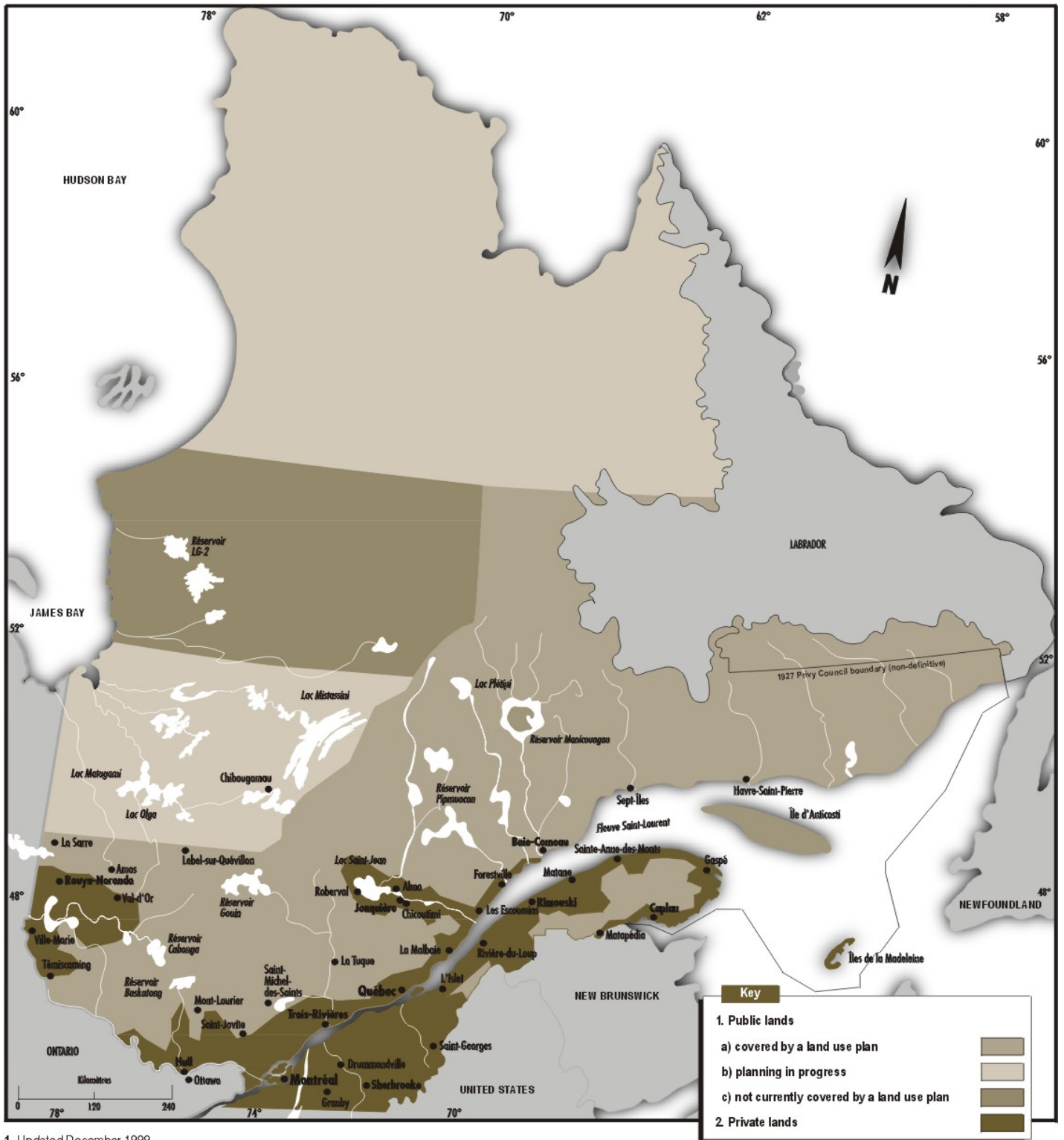

1. Updated December 1999.

2. In 2005, the government began the development of a new public land use plan for the regions of Saguenay--Lac-St-Jean, Capitale-Nationale, Mauricie, Outaouais, Abitibi-Témiscamingue, Côte-Nord, Gaspésie--Îles-de-la-Madeline and Laurentides.

Source : Direction générale de la gestion du territoire public.

1 Geographical distribution of Québec's forests

Administrative divisions in Québec's public forests ¹

01.05.02

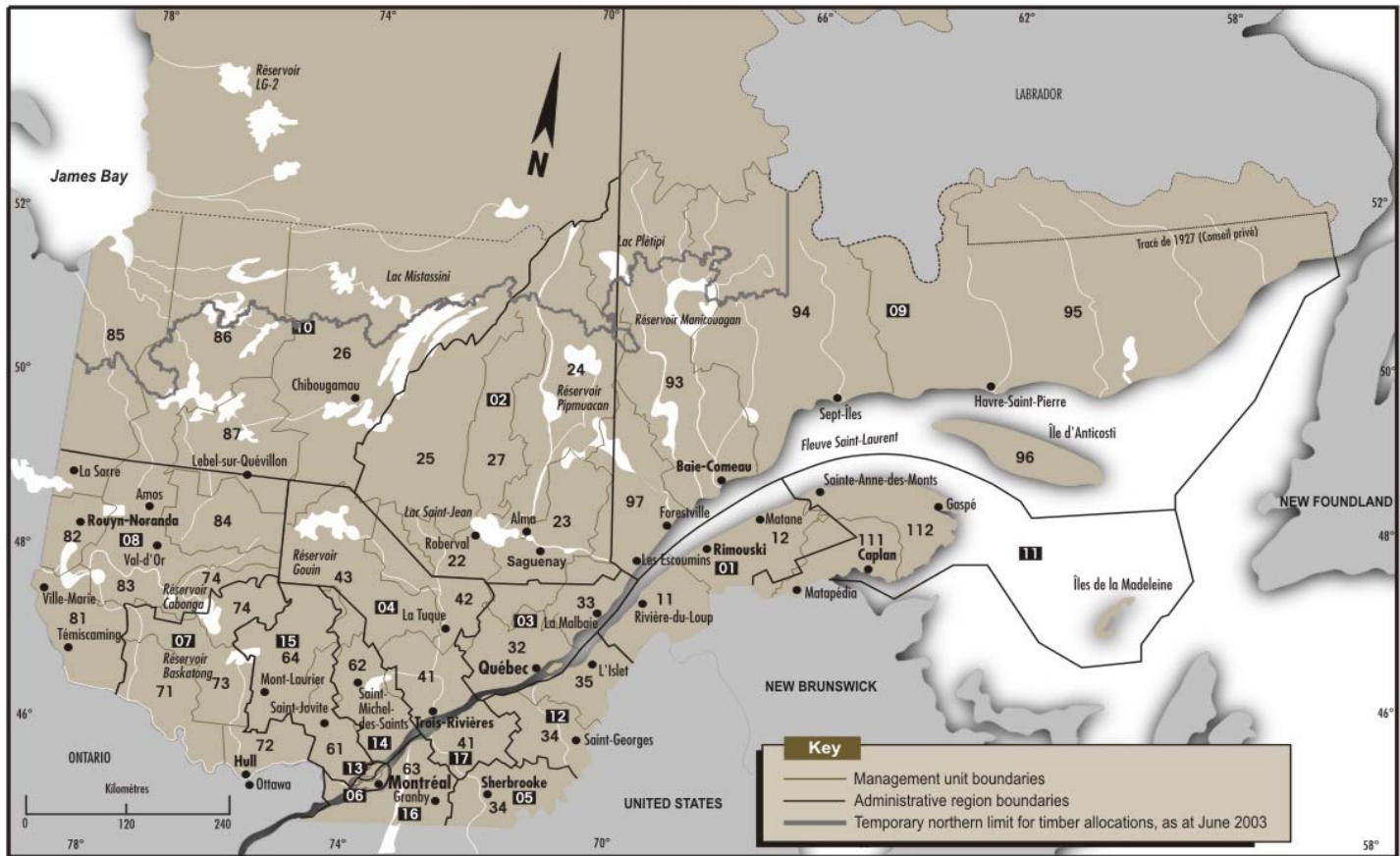

Key

ADMINISTRATIVE REGIONS	MANAGEMENT UNITS	ADMINISTRATIVE REGIONS	MANAGEMENT UNITS
01 Bas-Saint-Laurent	11-12 p. ² -111 p., 112 p.	09 Côte-Nord	24 p., 93 p., 94-95-96, 97 p.
02 Saguenay—Lac-Saint-Jean	23 p., 22-25, 24 p., 27, 33 p., 42-43 p., 93 p., 97 p.	10 Nord-du-Québec	26 p., 85 p., 86 p., 87 p.
03 Capital-Nationale	23 p., 32, 33 p.	11 Gaspésie—Îles-de-la-Madeleine	12 p., 111 p., 112 p.
04 Mauricie	26 p., 41 p., 42-43 p.	12 Chaudière-Appalaches	34 p.-35
05 Estrie	DGR 05-06-16 ³	13 Laval	63 p.
06 Montréal	DGR 05-06-16	14 Lanaudière	41 p., 42-43 p., 62 p., 64 p.
07 Outaouais	71, 72, 73-74 p.	15 Laurentides	61, 62 p., 64 p.
08 Abitibi-Témiscamingue	73-74 p., 81, 82, 83, 84, 85 p., 86 p., 87 p.	16 Montérégie	DGR 05-06-16
		17 Centre-du-Québec	41 p.

1 Updated august 2008
 2 p. : part of
 3 RDG : Regional directorate general

Note : This document provides figures for each of the Québec government's 17 administrative regions. However, for internal management purposes, the ministère des Ressources naturelles et de la Faune considers only 11 administrative regions, subdivided into 37 management units.

1 Geographical distribution of Québec's forest

Types of ownership and survey zones

Breakdown of Québec¹ by survey zone and type of ownership²

01.06.02

	Administrative regions																	Total
	01	02	03	04	05	06	07	08	09	10	11	12	13	14	15	16	17	
	(km ²)																	
UNSURVEYED ZONE																		
Québec public lands										260,771								260,771
Private lands (Inuit)										6,551								6,551
Federal lands																		
Total area										267,322								267,322
EXTENSIVE SURVEY ZONE³																		
Québec public lands		9,094							153,908	472,171								635,173
Forests in the domain of the State ⁴		9,094							153,908	472,171								635,173
Other tenures ⁵																		
Private lands									30	2,116								2,146
Large holdings ⁶										2,116								2,116
Small holdings									30									30
Federal lands									38	1,525								1,563
Total area		9,094							153,976	475,812								638,882
INTENSIVE SURVEY ZONE³																		
Québec public lands	11,574	90,658	12,472	31,388	756	93	25,669	57,393	113,286	89,976	16,190	1,603	9,109	15,228	588	95		476,077
Forests in the domain of the State	11,259	89,883	11,141	31,313	544	93	25,358	55,075	111,515	89,822	15,384	1,474	8,276	14,398	555	81		466,171
Other tenures	315	775	1,331	75	212		311	2,318	1,771	153	806	129	833	830	33	14		9,906
Private lands	11,105	6,619	6,716	7,701	9,695	514	7,904	7,188	1,928	1,089	3,995	13,649	267	4,384	6,818	11,154	6,974	107,701
Large holdings	1,126	882	2,323	3,726	1,310		489	142	953	862	125	685	2	33	33	60		12,752
Small holdings	9,979	5,737	4,393	3,975	8,385	514	7,415	7,046	976	226	3,870	12,964	267	4,382	6,786	11,121	6,914	94,948
Federal lands	2	26	610	818	5	15	545	26	3,099	1,258	289	226	8	478	103	263		7,771
Total area	22,681	97,303	19,798	39,908	10,456	622	34,118	64,607	118,314	92,322	20,474	15,478	267	13,501	22,525	11,845	7,332	591,549
Total (land)	22,681	106,397	19,798	39,908	10,456	622	34,118	64,607	272,290	835,456	20,474	15,478	267	13,501	22,525	11,845	7,332	1,497,753

1. Not including areas covered by the waters of the St. Lawrence River and Gulf, James Bay, Hudson Bay, Ungava Bay and the Hudson Strait

2. Updated September 2004.

3. The summary of surveyed forests in Chapter 2 covers the intensive survey zone only, since forest ecosystems in the extensive survey zone are so fragile that timber harvesting is prohibited.

4. Land supporting forest stands.

5. Forest stations, experimental and research forests, etc.

6. More than 800 hectares in a single block.

N.B. : Figures have been rounded off, which may have caused negligible errors in the totals.

1 Geographical distribution of Québec's forests

Private forests

Regional agencies for private forest development ¹

01.07.01

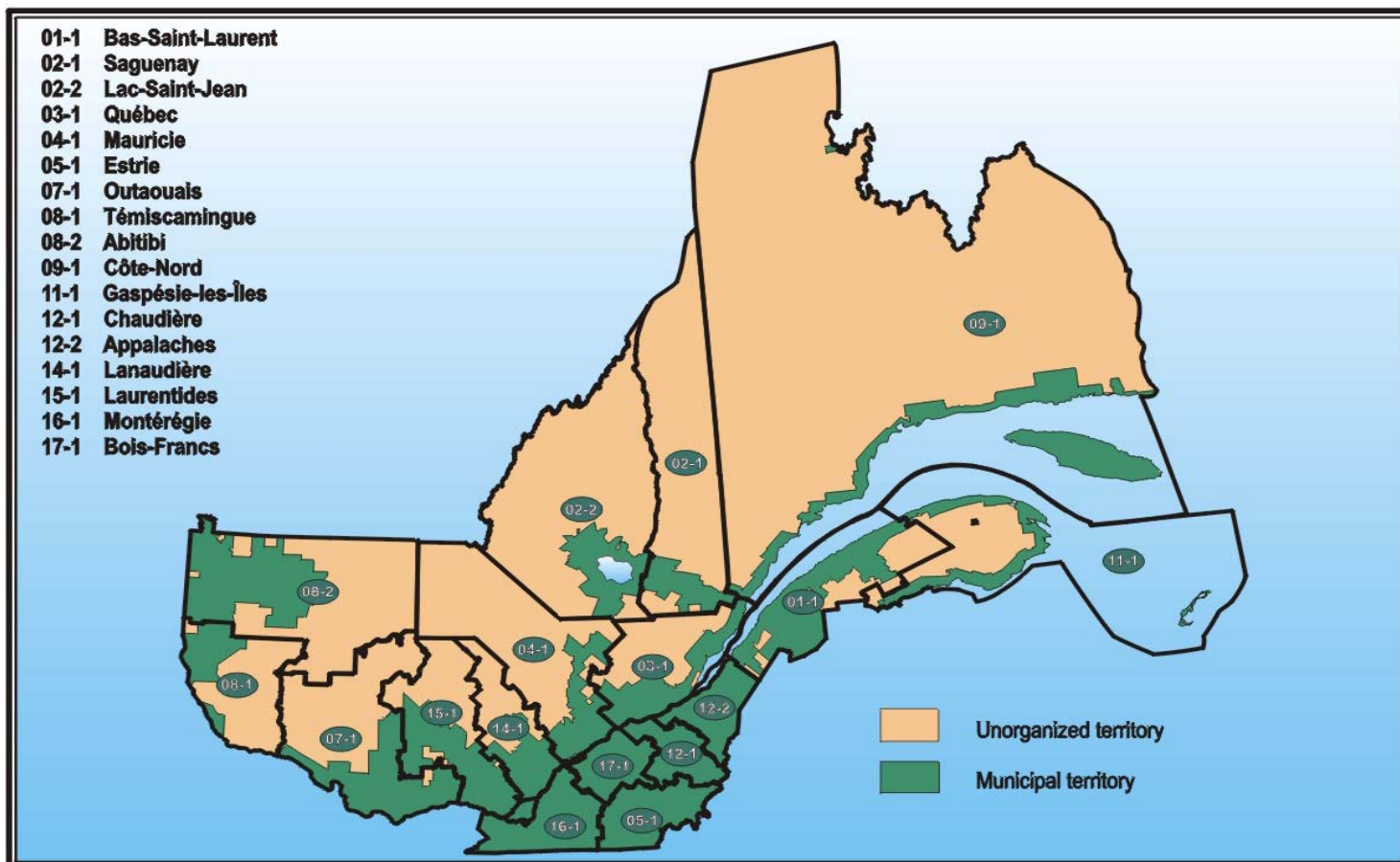

1. Updated April 2002.

Regional agencies

No.	Administrative regions	Name of agency	Number of owners ¹	Active owners (%) ²
01-1	Bas-Saint-Laurent	Agence régionale de mise en valeur des forêts privées du Bas-Saint-Laurent	10,600	61
02-1	Saguenay	Agence régionale de mise en valeur des forêts privées du Saguenay	2,400	40
02-2	Lac-Saint-Jean	Agence régionale de mise en valeur des forêts privées du Lac-Saint-Jean	3,600	40
03-1	Québec	Agence des forêts privées de Québec 03 (AFPQ)	6,500	85
04-1	Mauricie	Agence régionale de mise en valeur des forêts privées mauriciennes	6,600	52
05-1	Estrie	Agence régionale de mise en valeur des forêts privées de l'Estrie (AMFE)	9,200	65
07-1	Outaouais	Agence régionale de mise en valeur des forêts privées outaouaises	10,900	61
08-1	Témiscamingue	Agence régionale de mise en valeur des forêts privées du Témiscamingue (ARMVFPT)	1,900	20
08-2	Abitibi	Agence régionale de mise en valeur des forêts privées de l'Abitibi	6,300	25
09-1	Côte-Nord	Agence régionale de mise en valeur des forêts privées de la Côte-Nord	850	62
11-1	Gaspésie-les-Îles	Agence régionale de mise en valeur des forêts privées de la Gaspésie-les-Îles (AFOGIM)	5,000	40
12-1	Chaudière	Agence régionale de mise en valeur des forêts privées de la Chaudière	11,500	81
12-2	Appalaches	Agence régionale de mise en valeur des forêts privées des Appalaches	12,800	79
14-1	Lanaudière	Agence régionale de mise en valeur des forêts privées de Lanaudière	8,300	54
15-1	Laurentides	Agence régionale de mise en valeur des forêts privées des Laurentides	13,400	12
16-1	Montérégie	Agence forestière de la Montérégie	10,500	66
17-1	Bois-Francs	Agence forestière des Bois-Francs (AFBF)	9,500	72
Total			129,850	57

1. Number of woodlot owners (4 ha and over) per development agency.

2. Percentage of active owners over a five-year period.

Source : Private Forest Protection and Development Plan (April 2002).

1 Geographical distribution of Québec's forests

Private forests (cont'd)

Areas covered by syndicates and wood marketing boards ¹

01.07.04

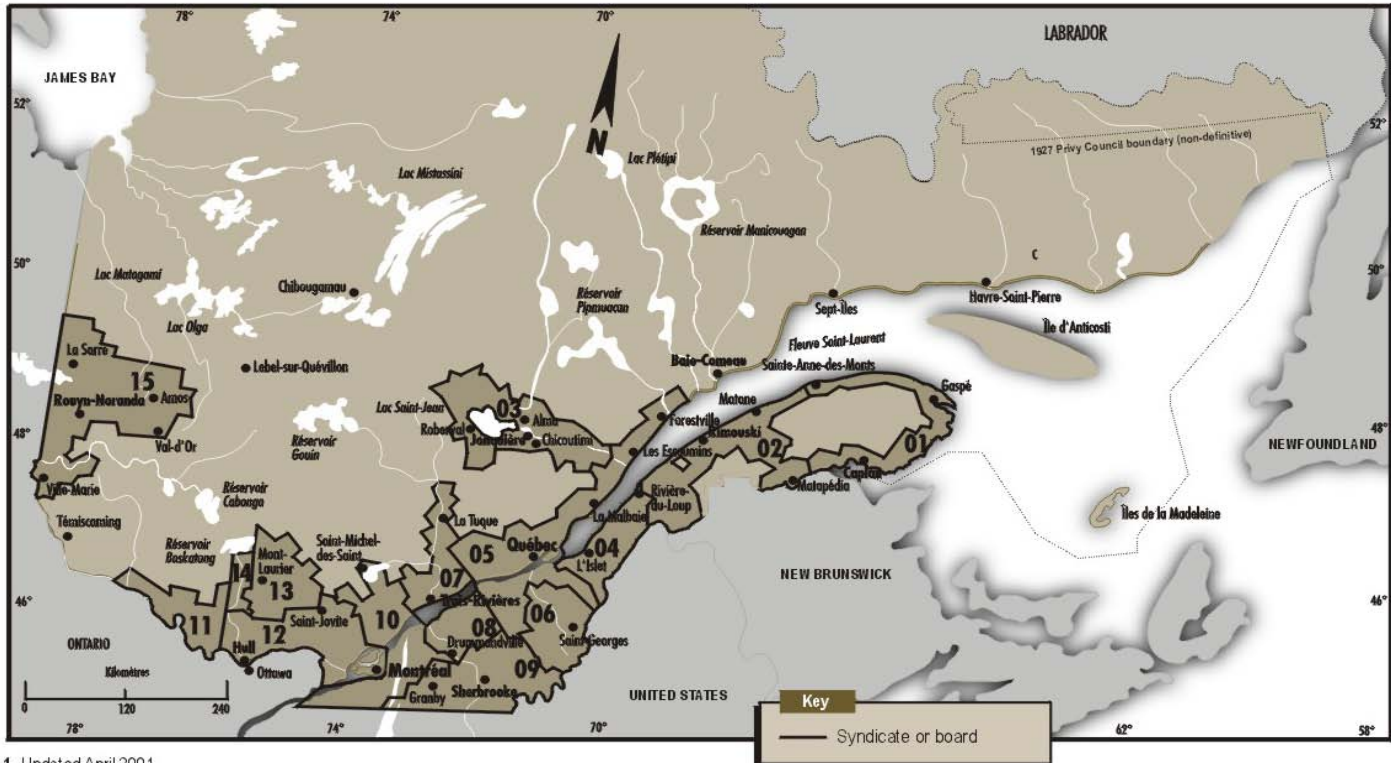

1. Updated April 2001.

Syndicates or boards

- 01 - Syndicat des producteurs de bois de la Gaspésie
- 02 - Syndicat des producteurs de bois du Bas-Saint-Laurent
- 03 - Syndicat des producteurs de bois du Saguenay—Lac-Saint-Jean
- 04 - Syndicat des producteurs de bois de la Côte-du-Sud
- 05 - Syndicat des producteurs de bois de la région de Québec
- 06 - Syndicat des producteurs de bois de la Beauce
- 07 - Syndicat des producteurs de bois de la Mauricie
- 08 - Syndicat des producteurs de bois du Centre-du-Québec
- 09 - Syndicat des producteurs de bois de l'Estrie
- 10 - Syndicat des producteurs de bois de la région de Montréal
- 11 - Office des producteurs de bois du Pontiac
- 12 - Syndicat des producteurs de bois Outaouais-Laurentides
- 13 - Syndicat des producteurs de bois du comté de Labelle
- 14 - Office des producteurs de bois de la Gatineau
- 15 - Syndicat des producteurs de bois d'Abitibi-Témiscamingue

2 Intensive survey zone

Highlights

02.00.01

Land survey	Area (km ²)	Gross merchantable Volume (m ³ , 000s)
Intensive survey zone ¹	591,549	
Bodies of water	-58,302	
Non-forest land	-34,894	
Forest land	498,353	
Unproductive forest land	-62,838	
Productive forest land (grades of 41 % and over)	-11,401	
Productive forest land (grades between 0 % and 40 %)	424,114	3,791,919
• Québec public lands	355,004	3,124,029
• Small private holdings	55,306	546,006
• Large private holdings	10,940	91,472
• Federal lands	2,864	30,413

1. Area in which the ministère des Ressources naturelles et de la Faune conducts detailed forest surveys

2 Intensive survey zone

Area of productive forests (grades between 0 % and 40 %) ¹ and available gross merchantable volume

02.03.01

By age, forest type and administrative region

		Administrative regions								Subtotal ²	
		01		02		03		04		(km ²)	(m ³ , 000s)
		(km ²)	(m ³ , 000s)	(km ²)	(m ³ , 000s)	(km ²)	(m ³ , 000s)	(km ²)	(m ³ , 000s)		
Total area²		18,357	163,407	74,990	560,943	15,657	121,645	31,343	331,490	140,347	1,177,485
By age	0-10 years	4,826	2,092	16,943	2,010	2,667	1,218	5,684	321	30,120	5,641
	30 years	1,788	12,900	8,046	28,970	3,104	12,820	2,862	17,288	15,800	71,979
	50 years	6,770	81,711	10,495	98,380	5,093	51,862	7,863	88,950	30,221	320,903
	70 years	3,299	44,337	12,121	137,733	2,216	24,258	7,876	127,346	25,512	333,673
	90 years	1,422	19,231	9,207	100,506	2,328	29,744	5,478	78,484	18,436	227,966
	120 years	252	3,135	18,178	193,344	249	1,743	1,580	19,102	20,259	217,323
By forest type	Softwood	6,716	63,077	45,144	395,525	5,535	38,191	10,243	109,217	67,638	606,009
	Mixedwood	6,249	58,749	15,138	112,684	5,883	48,558	12,931	147,688	40,201	367,679
	Hardwood	3,975	41,581	5,601	52,735	3,243	34,897	6,092	74,585	18,912	203,798
	Regenerating	1,418		9,107		996		2,077		13,597	
Québec public lands²		10,593	98,401	70,870	535,412	10,670	76,530	25,531	279,466	117,664	989,809
By age	0-10 years	2,773	70	15,678	579	1,787	38	4,351	74	24,590	762
	30 years	847	5,461	6,990	22,654	2,212	8,006	2,205	12,376	12,254	48,498
	50 years	2,949	38,821	8,992	83,516	3,044	28,950	5,632	63,713	20,617	215,001
	70 years	2,598	35,294	11,881	135,362	1,698	18,059	7,369	120,440	23,547	309,155
	90 years	1,207	16,054	9,161	100,053	1,682	19,768	4,631	66,563	16,681	202,438
	120 years	219	2,700	18,167	193,247	246	1,709	1,343	16,299	19,975	213,955
By forest type	Softwood	4,748	46,952	44,226	390,017	4,672	31,634	8,598	96,456	62,245	565,059
	Mixedwood	3,263	31,650	13,529	101,053	3,660	28,261	10,848	126,973	31,300	287,937
	Hardwood	1,768	19,799	4,532	44,342	1,656	16,635	4,451	56,037	12,407	136,812
	Regenerating	814		8,583		682		1,634		11,713	
Small private holdings²		6,707	56,117	3,335	21,292	2,772	25,729	2,274	24,516	15,088	127,655
By age	0-10 years	1,775	2,022	985	1,375	546	1,136	430	206	3,736	4,739
	30 years	747	6,093	841	5,312	477	2,969	362	3,305	2,426	17,679
	50 years	3,559	39,838	1,335	13,088	1,343	15,445	994	13,215	7,230	81,587
	70 years	484	6,031	169	1,493	131	1,600	214	3,158	999	12,282
	90 years	139	2,065	6	23	275	4,579	273	4,620	693	11,287
	120 years	3	69					1	12	4	81
By forest type	Softwood	1,385	9,450	591	3,558	436	2,988	314	2,449	2,726	18,445
	Mixedwood	2,742	25,565	1,389	10,359	1,194	11,163	879	9,511	6,204	56,599
	Hardwood	2,069	21,103	968	7,375	981	11,578	979	12,556	4,997	52,612
	Regenerating	510		387		161		102		1,161	
Large private holdings²		1,056	8,868	774	4,136	2,022	17,287	3,033	20,324	6,885	50,615
By age	0-10 years	278		278	55	308	43	891	38	1,754	136
	30 years	194	1,346	213	975	404	1,795	292	1,583	1,102	5,699
	50 years	262	3,046	163	1,725	633	6,557	1,195	11,525	2,253	22,852
	70 years	215	2,998	69	855	345	4,112	179	2,130	808	10,095
	90 years	76	1,112	40	430	330	4,746	337	3,837	783	10,125
	120 years	30	366	11	97	2	34	141	1,210	184	1,706
By forest type	Softwood	583	6,673	327	1,947	401	3,376	1,269	9,548	2,580	21,544
	Mixedwood	243	1,529	216	1,235	956	8,208	914	6,779	2,329	17,751
	Hardwood	137	665	95	955	528	5,703	516	3,997	1,276	11,320
	Regenerating	93		135		137		335		700	
Federal lands²		2	21	10	103	192	2,099	505	7,184	709	9,407
By age	0-10 years	0		2	1	26		13	2	40	3
	30 years	0		3	29	11	51	3	23	17	102
	50 years	0	7	4	51	73	910	42	496	121	1,463
	70 years	1	14	2	22	41	487	114	1,617	157	2,141
	90 years		0			41	652	237	3,464	278	4,116
	120 years					0	0	95	1,581	96	1,581
By forest type	Softwood	0	1	0	3	25	193	62	763	87	961
	Mixedwood	1	6	3	36	73	925	291	4,425	368	5,392
	Hardwood	1	14	6	63	79	981	146	1,996	231	3,054
	Regenerating	0		1		16		6		23	

1. Updated September 2004.

2. The figures have been rounded off, which may have caused negligible errors.

2 Intensive survey zone

Area of productive forests (grades between 0 % and 40 %) ¹ and available gross merchantable volume (cont'd)

02.03.01

By age, forest type and administrative region (cont'd)

		Administrative regions								Subtotal ²	
		05		06		07		08			
		(km ²)	(m ³ , 000s)	(km ²)	(m ³ , 000s)	(km ²)	(m ³ , 000s)	(km ²)	(m ³ , 000s)	(km ²)	(m ³ , 000s)
Total area²		7,668	87,691	41	319	27,239	365,699	48,594	447,449	83,543	901,157
By age	0-10 years	1,620	212	20	3	2,570	6,426	8,490	2,128	12,700	8,769
	30 years	1,328	12,604	7	61	1,630	13,782	5,792	26,012	8,757	52,459
	50 years	3,603	55,106	11	190	7,953	119,826	9,665	98,437	21,232	273,558
	70 years	329	5,061			4,990	69,120	11,140	145,627	16,460	219,807
	90 years	787	14,701	3	65	9,727	152,527	10,242	138,637	20,758	305,930
	120 years	1	8			369	4,018	3,265	36,609	3,635	40,634
By forest type	Softwood	1,269	13,214	0	3	3,474	37,245	17,687	146,247	22,431	196,709
	Mixedwood	2,818	31,999	3	24	10,429	143,927	17,092	178,043	30,342	353,993
	Hardwood	2,979	42,478	22	292	12,370	184,527	10,942	123,160	26,313	350,456
	Regenerating	601		16		966		2,874		4,457	
Québec public lands²		679	9,602			21,551	286,729	44,910	422,327	67,140	718,657
By age	0-10 years	70	5			1,875	5,184	7,395	1,916	9,341	7,105
	30 years	58	484			1,326	10,382	5,197	22,057	6,581	32,922
	50 years	294	4,951			4,778	69,612	8,153	82,573	13,226	157,136
	70 years	108	1,621			4,259	57,473	10,766	141,269	15,132	200,363
	90 years	149	2,535			8,947	140,126	10,201	138,258	19,297	280,919
	120 years	1	7			366	3,952	3,197	36,254	3,564	40,213
By forest type	Softwood	108	1,012			2,992	29,833	17,128	143,116	20,227	173,961
	Mixedwood	273	3,525			8,510	114,009	16,237	170,569	25,020	288,104
	Hardwood	288	5,064			9,494	142,887	9,088	108,641	18,871	256,592
	Regenerating	10				555		2,457		3,022	
Small private holdings²		5,746	62,993	40	317	4,839	66,596	3,553	24,138	14,177	154,044
By age	0-10 years	1,279	174	19	3	644	1,114	1,087	212	3,029	1,503
	30 years	1,139	10,959	6	59	270	3,090	568	3,844	1,983	17,952
	50 years	2,785	41,542	11	190	2,682	42,440	1,482	15,617	6,961	99,789
	70 years	130	2,049			628	10,012	365	4,232	1,123	16,293
	90 years	412	8,269	3	65	614	9,938	19	167	1,048	18,439
	120 years					0	2	33	65	33	67
By forest type	Softwood	994	10,466	0	3	445	6,800	472	2,531	1,911	19,799
	Mixedwood	2,160	24,097	3	24	1,707	26,598	826	7,212	4,695	57,932
	Hardwood	2,059	28,430	21	290	2,296	33,198	1,839	14,395	6,215	76,313
	Regenerating	533		15		391		416		1,356	
Large private holdings²		1,242	15,079			405	5,712	113	866	1,759	21,657
By age	0-10 years	271	33			37	115	3		310	147
	30 years	131	1,161			24	204	22	76	177	1,442
	50 years	522	8,596			208	3,294	23	185	753	12,074
	70 years	91	1,391			40	669	8	104	140	2,164
	90 years	226	3,897			93	1,365	22	212	340	5,474
	120 years	0	1			3	64	35	290	39	355
By forest type	Softwood	167	1,733			19	327	85	588	271	2,648
	Mixedwood	386	4,373			106	1,680	23	235	515	6,289
	Hardwood	631	8,973			270	3,704	4	43	905	12,720
	Regenerating	58				9		0		67	
Federal lands²		1	17	1	2	445	6,662	19	118	467	6,800
By age	0-10 years	0		1		13	13	6		20	13
	30 years	0	0	0	2	10	106	6	35	16	143
	50 years	1	17			285	4,480	6	62	292	4,559
	70 years	0				63	966	2	21	65	987
	90 years					74	1,098	0	0	74	1,098
	120 years										
By forest type	Softwood	0	3			19	285	2	13	21	300
	Mixedwood	0	4			105	1,639	6	26	111	1,669
	Hardwood	1	10	0	2	310	4,739	11	80	322	4,831
	Regenerating	0		1		11		1		13	

1. Updated September 2004.

2. The figures have been rounded off, which may have caused negligible errors.

2 Intensive survey zone

Area of productive forests (grades between 0 % and 40 %) ¹ and available gross merchantable volume (cont'd)

02.03.01

By age, forest type and administrative region (cont'd)

		Administrative regions								Subtotal ²	
		09		10		11		12			
		(km ²)	(m ³ , 000s)	(km ²)	(m ³ , 000s)	(km ²)	(m ³ , 000s)	(km ²)	(m ³ , 000s)	(km ²)	(m ³ , 000s)
Total area²		80,293	661,885	57,768	389,011	16,383	137,961	10,920	94,021	165,365	1,282,878
By age	0-10 years	11,995	15	15,722	440	3,242	66	2,997	1,694	33,956	2,214
	30 years	5,699	12,111	3,461	5,323	2,637	11,820	1,774	13,755	13,571	43,008
	50 years	6,601	53,148	2,927	17,634	5,173	57,980	4,475	54,459	19,176	183,221
	70 years	6,223	67,221	13,160	162,523	2,615	33,214	809	10,129	22,807	273,087
	90 years	23,201	253,282	5,858	60,685	2,195	29,070	859	13,901	32,112	356,937
	120 years	26,575	276,108	16,640	142,406	521	5,813	7	84	43,743	424,411
By forest type	Softwood	61,782	587,209	39,117	321,515	7,194	67,647	2,468	21,264	110,560	997,635
	Mixedwood	8,165	59,267	7,368	54,342	6,141	51,515	4,709	38,727	26,384	203,851
	Hardwood	1,725	15,409	1,734	13,153	1,938	18,799	2,694	34,031	8,090	81,392
	Regenerating	8,622		9,549		1,111		1,050		20,331	
Québec public lands²		78,693	650,956	56,061	376,339	13,271	110,335	1,493	14,705	149,519	1,152,336
By age	0-10 years	11,718	15	15,446	434	2,594	6	420	15	30,178	470
	30 years	5,468	11,306	3,378	4,986	2,105	8,477	83	474	11,033	25,244
	50 years	5,967	47,533	2,824	16,732	3,886	42,843	373	5,608	13,050	112,717
	70 years	6,051	65,539	13,017	160,956	2,158	26,968	439	5,880	21,664	259,344
	90 years	22,969	250,960	5,323	55,829	2,014	26,288	171	2,644	30,476	335,721
	120 years	26,520	275,602	16,074	137,401	516	5,753	7	83	43,117	418,840
By forest type	Softwood	60,940	580,762	37,884	311,467	6,467	61,657	532	5,252	105,823	959,138
	Mixedwood	7,664	55,846	7,165	52,156	4,534	36,609	590	5,917	19,952	150,528
	Hardwood	1,590	14,348	1,688	12,716	1,307	12,069	218	3,536	4,803	42,669
	Regenerating	8,500		9,325		963		153		18,940	
Small private holdings²		578	3,882	138	808	2,780	24,845	8,773	72,706	12,270	102,241
By age	0-10 years	99		44	4	607	58	2,389	1,664	3,139	1,726
	30 years	91	339	31	176	473	3,077	1,638	12,911	2,233	16,504
	50 years	304	2,704	37	352	1,158	13,835	3,818	44,542	5,318	61,432
	70 years	34	324	17	183	380	5,350	293	3,206	724	9,063
	90 years	42	444	4	45	158	2,482	635	10,383	839	13,355
	120 years	8	70	6	48	4	43			18	161
By forest type	Softwood	212	1,419	46	286	647	5,323	1,804	14,862	2,710	21,891
	Mixedwood	236	1,686	31	258	1,437	13,489	3,799	29,787	5,503	45,221
	Hardwood	82	777	36	263	560	6,033	2,332	28,056	3,010	35,129
	Regenerating	48		26		136		837		1,048	
Large private holdings²		722	5,050	698	5,195	104	792	655	6,610	2,179	17,647
By age	0-10 years	117		139	1	20		188	14	464	15
	30 years	122	397	35	127	33	173	53	369	243	1,067
	50 years	220	2,074	40	350	25	262	283	4,309	569	6,995
	70 years	104	1,028	53	572	19	239	78	1,043	254	2,882
	90 years	124	1,251	163	1,673	6	107	53	874	347	3,904
	120 years	34	300	267	2,473	1	10	0	0	302	2,784
By forest type	Softwood	457	3,604	471	4,060	50	423	131	1,149	1,109	9,235
	Mixedwood	180	1,196	100	1,060	50	352	320	3,022	650	5,630
	Hardwood	45	250	6	75	3	17	144	2,439	198	2,781
	Regenerating	40		120		1		60		222	
Federal lands²		300	1,997	870	6,667	228	1,990			1,398	10,655
By age	0-10 years	60		93	2	21	2			174	3
	30 years	18	68	17	33	26	92			61	193
	50 years	110	838	26	200	105	1,039			240	2,077
	70 years	33	330	74	811	58	657			165	1,798
	90 years	66	627	367	3,138	17	193			450	3,958
	120 years	13	135	293	2,483	0	7			307	2,626
By forest type	Softwood	173	1,424	716	5,702	29	244			918	7,370
	Mixedwood	86	538	72	867	121	1,066			279	2,471
	Hardwood	7	36	5	98	67	680			79	814
	Regenerating	34		77		11				121	

1. Updated September 2004.

2. The figures have been rounded off, which may have caused negligible errors.

2 Intensive survey zone

Area of productive forests (grades between 0 % and 40 %) ¹ and available gross merchantable volume (cont'd)

02.03.01

By age, forest type and administrative region (cont'd)

		Administrative regions										Total ²	
		13		14		15		16		17			
		(km ²)	(m ³ , 000s)	(km ²)	(m ³ , 000s)	(km ²)	(m ³ , 000s)	(km ²)	(m ³ , 000s)	(km ²)	(m ³ , 000s)	(km ²)	(m ³ , 000s)
Total area²		61	362	9,892	115,745	17,811	241,717	3,591	41,930	3,504	30,644	424,115	3,791,919
By age	0-10 years	31		1,610	323	1,717	2,241	564	219	787	694	81,487	20,100
	30 years	14	108	879	6,657	1,065	7,695	837	7,790	761	5,078	41,685	194,774
	50 years	15	233	3,042	42,239	6,233	92,904	1,654	23,516	1,790	21,722	83,364	958,296
	70 years	0	1	2,461	38,162	2,822	41,348	114	1,923	37	489	70,213	908,491
	90 years	1	20	1,764	26,919	5,634	93,102	422	8,482	129	2,662	79,255	1,022,017
	120 years			135	1,446	340	4,427					68,112	688,241
By forest type	Softwood			1,399	15,153	2,450	25,815	212	2,936	548	4,150	205,237	1,848,406
	Mixedwood	8	63	4,838	58,891	6,328	86,264	815	11,159	973	10,031	109,889	1,091,929
	Hardwood	25	299	3,320	41,702	8,617	129,638	2,255	27,835	1,705	16,463	69,236	851,584
	Regenerating	28		335		416		310		279		39,753	
Québec public lands²				7,596	88,090	12,995	174,262	23	227	67	648	355,004	3,124,029
By age	0-10 years			1,264	249	1,093	1,331	7	2	11	4	66,482	9,922
	30 years			635	4,272	861	5,863	5	46	12	79	31,382	116,923
	50 years			1,755	23,796	3,326	47,417	6	92	38	463	52,018	556,621
	70 years			2,159	33,552	2,434	34,885	0	5	3	37	64,938	837,342
	90 years			1,648	24,775	4,947	80,471	5	83	4	66	73,059	924,473
	120 years			135	1,446	334	4,296					67,125	678,749
By forest type	Softwood			1,240	13,244	2,091	21,559	1	11	14	123	191,640	1,733,097
	Mixedwood			3,959	47,633	4,787	63,208	3	31	28	309	85,049	837,749
	Hardwood			2,170	27,213	5,938	89,496	15	185	22	216	44,225	553,183
	Regenerating			228		179		4		4		34,090	
Small private holdings²		61	362	2,287	27,560	4,567	64,130	3,479	40,601	3,377	29,413	55,307	546,006
By age	0-10 years	31		345	74	587	908	539	200	763	681	12,170	9,831
	30 years	14	108	244	2,383	185	1,652	825	7,677	739	4,936	8,648	68,892
	50 years	15	233	1,285	18,418	2,785	43,596	1,609	22,826	1,731	21,019	26,933	348,900
	70 years	0	1	302	4,597	354	5,943	111	1,876	32	415	3,645	50,470
	90 years	1	20	112	2,088	650	11,901	395	8,021	112	2,362	3,850	67,473
	120 years					6	131					61	440
By forest type	Softwood			159	1,909	335	3,946	210	2,917	524	3,974	8,574	72,880
	Mixedwood	8	63	876	11,224	1,466	21,917	807	11,044	930	9,541	20,489	213,539
	Hardwood	25	299	1,146	14,428	2,560	38,267	2,169	26,640	1,652	15,898	21,774	259,586
	Regenerating	28		107		207		293		271		4,470	
Large private holdings²				2	35	29	500	31	502	55	517	10,940	91,472
By age	0-10 years			0		0	1	3	8	13	9	2,545	316
	30 years					2	23	1	7	10	60	1,535	8,297
	50 years			1	9	11	187	11	182	17	180	3,615	42,480
	70 years			0	6	4	69	1	25	2	35	1,209	15,277
	90 years			1	19	11	221	16	281	13	234	1,511	20,257
	120 years											524	4,846
By forest type	Softwood					3	34	1	8	9	48	3,972	33,518
	Mixedwood			1	15	9	173	3	58	15	174	3,523	30,091
	Hardwood			1	19	17	293	27	436	27	294	2,451	27,863
	Regenerating					0		0		5		994	
Federal lands²				7	61	221	2,824	58	600	5	67	2,864	30,413
By age	0-10 years			2		37	1	16	10	1		290	31
	30 years			0	2	17	158	7	60	0	5	120	663
	50 years			1	16	111	1,704	29	416	4	61	797	10,296
	70 years			0	5	30	452	1	17	0	1	420	5,402
	90 years			3	37	26	509	5	96			836	9,814
	120 years											402	4,207
By forest type	Softwood			1	0	22	275			1	5	1,050	8,912
	Mixedwood			2	19	66	966	2	26	1	7	828	10,550
	Hardwood			3	42	103	1,582	44	574	4	55	786	10,951
	Regenerating					30		12		0		200	

1. Updated September 2004.

2. The figures have been rounded off, which may have caused negligible errors.

3 Forest protection in Québec

Highlights

Area affected by spruce budworms (ha, 000s)

03.00.01

	2007	2008	2009
Light defoliation	33.2	27.6	67.7
Moderate defoliation	35.3	49.8	105.8
Severe defoliation	42.2	56.2	147.7
Total area affected	110.7	133.6	321.1

Forest fires

	2007	2008	2009
Intensive protection zone			
• Fires (no.)	892	189	441
• Area disturbed (ha, 000s)	278.0	0.1	17.9
• Fire control and firefighting costs (\$, million)	108.8	50.8	74.0
• Relative importance of fires caused by lightning ¹ (%)			
- Number	31	32	34
- Area disturbed	95	87	88
	2007	2008	2009
Limited protection zone			
• Fires (no.)	43	33	42
• Area disturbed (ha, 000s)	64.7	1.4	76.0
• Fire control and firefighting costs (\$, million)	1.3	0.8	1.1

1. Lightning was the main cause of forest fires in Québec during the period 1999-2008.

3 Forest protection in Québec

Insects and diseases

Areas damaged by defoliator insects

03.02.01

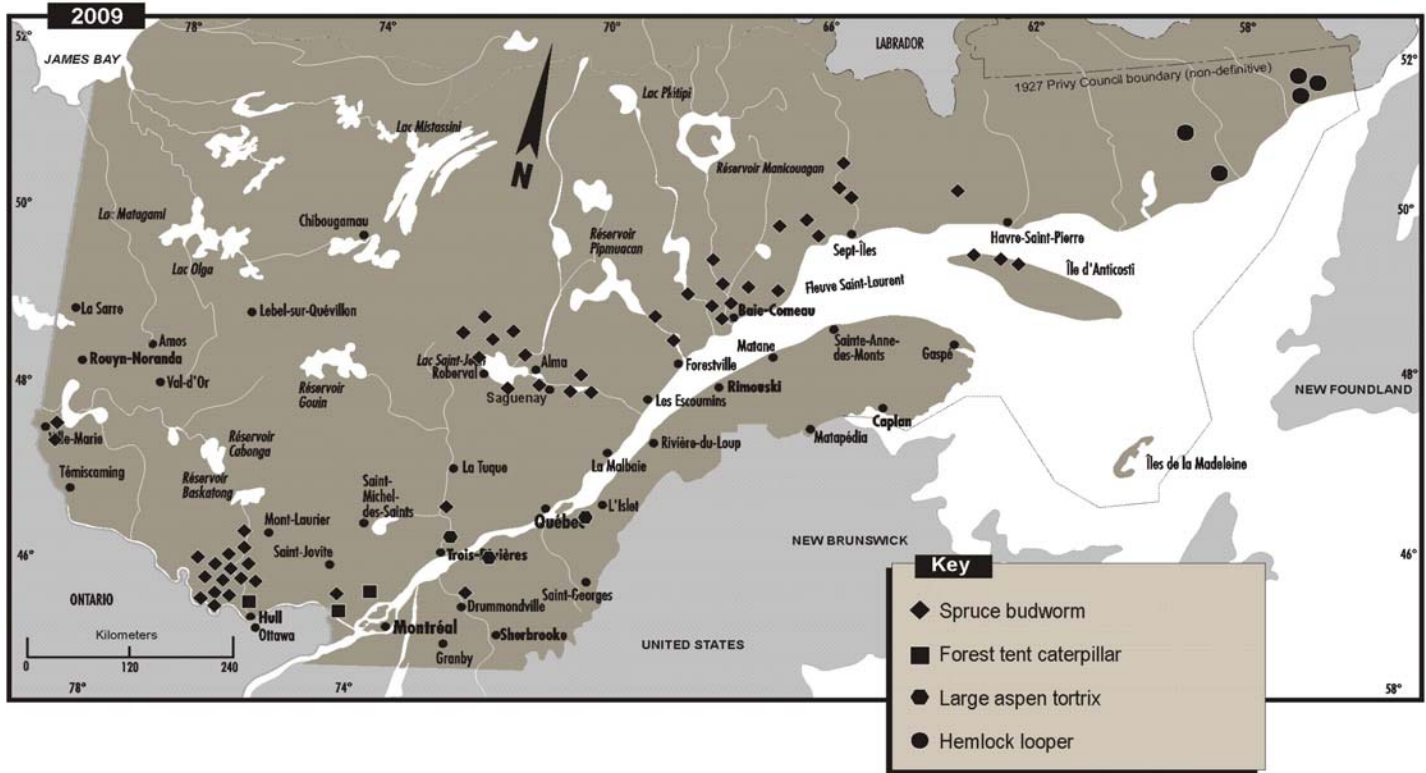
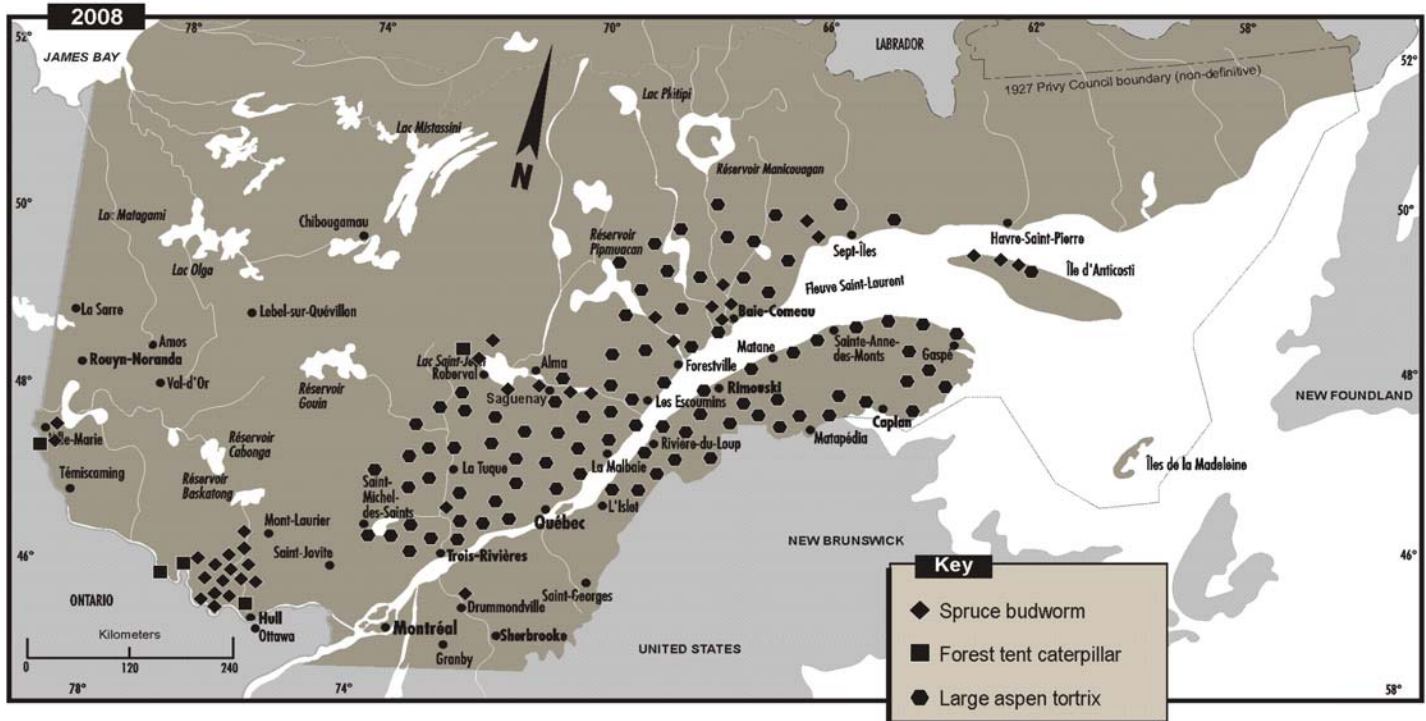

3 Forest protection in Québec

Forest fires

Areas damaged by fires

03.03.01

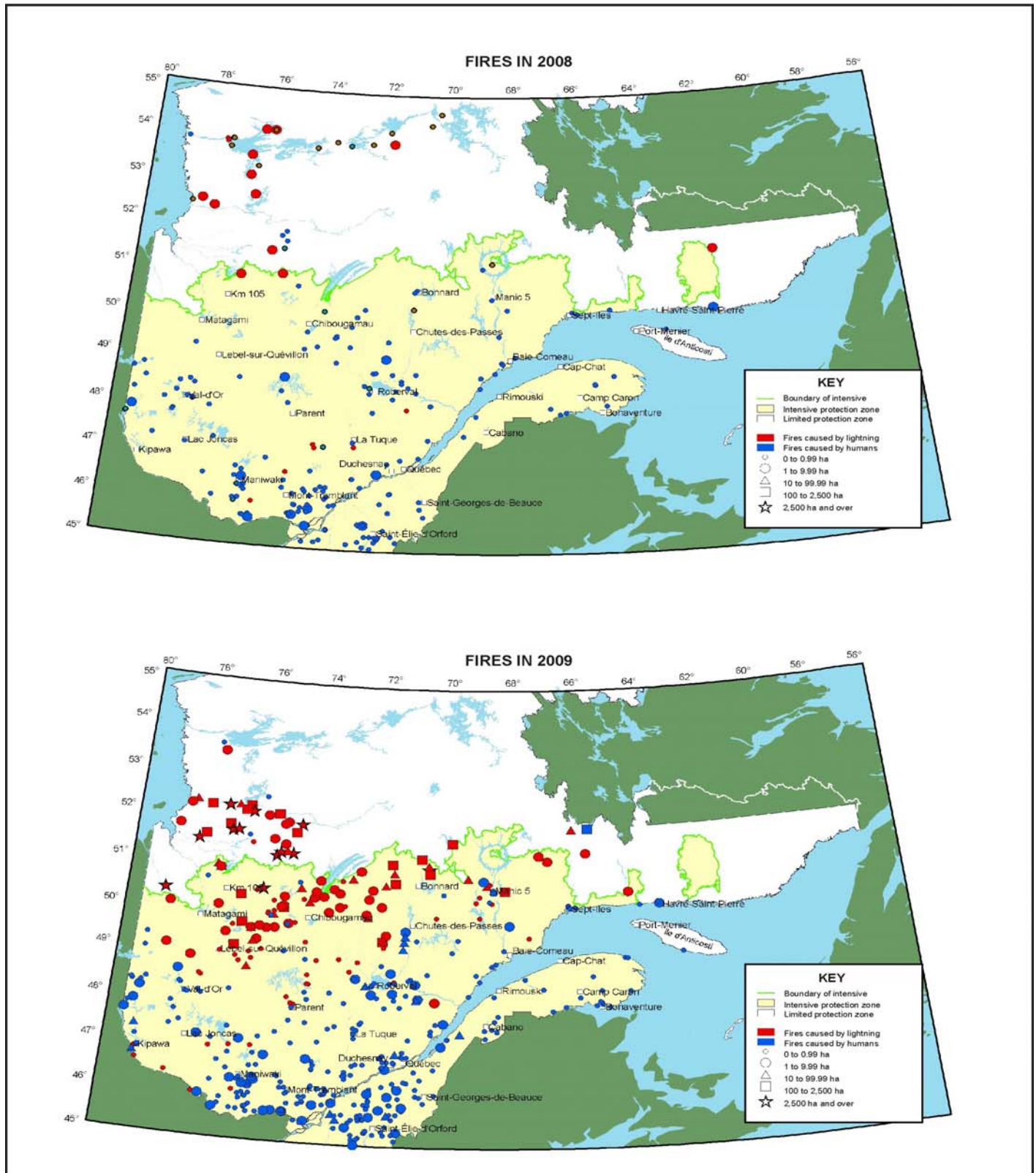

3 Forest protection in Québec

Forest fires (cont'd)

Intensive protection zone

Breakdown of forest fires by administrative region

03.03.07

Administrative regions		2004	2005	2006	2007	2008	2009	Total
01 Bas-Saint-Laurent	no.	5	14	12	5	3	14	53
	ha	1	5	2	2	0	19	29
02 Saguenay—Lac-Saint-Jean	no.	27	207	97	233	32	66	662
	ha	29	259,846	1,011	162,315	23	6,741	429,965
03 Capitale-Nationale	no.	9	14	19	24	5	22	93
	ha	3	11	32	57	4	41	148
04 Mauricie ¹	no.	29	60	54	81	12	32	268
	ha	13	28	67	330	6	3	447
05 Estrie	no.	6	18	3	9	21	21	78
	ha	0	18	1	8	4	31	62
06 Montréal	no.							0
	ha							0
07 Outaouais	no.	38	143	36	126	22	36	401
	ha	18	97	22	68	16	13	234
08 Abitibi-Témiscamingue	no.	33	249	85	156	20	39	582
	ha	33	11,749	153	61,701	11	138	73,785
09 Côte-Nord	no.	24	153	62	60	16	34	349
	ha	12	26,022	888	28,933	5	1,475	57,335
10 Nord-du-Québec	no.	10	170	158	53	7	58	456
	ha	5	88,734	11,553	24,556	9	9,391	134,248
11 Gaspésie—Îles-de-la-Madeleine	no.	23	11	14	7	6	13	74
	ha	72	2	3		0	3	80
12 Chaudière-Appalaches	no.	14	19	15	18	2	13	81
	ha	8	8	3	4	0	8	31
13 Laval	no.							0
	ha							0
14 Lanaudière	no.	33	72	18	41	13	22	199
	ha	24	50	2	12	2	8	98
15 Laurentides	no.	37	85	30	64	17	35	268
	ha	7	55	16	37	7	31	153
16 Montérégie	no.	7	28	15	9	9	20	88
	ha	31	30	14	7	45	34	161
17 Centre-du-Québec	no.	5	15	5	6	4	16	51
	ha	2	16	1	3	1	12	35
Total	no.	300	1,258	623	892	189	441	3,703
	ha	258	386,671	13,768	278,033	133	17,948	696,811

1. This breakdown has been made according to the boundaries of the administrative regions established in November of 2006

4 Sustainable development of Québec's forests

Highlights

Sustainable development criteria

04.00.01

- 1 - Preservation of biological diversity
- 2 - Maintenance and improvement of the conditions and productivity of forest ecosystems
- 3 - Conservation of soil and water resources
- 4 - Maintenance of the function of forest ecosystems as a component of global ecological cycles
- 5 - Maintenance of the multiple socio-economic benefits society derives from the forests
- 6 - Giving of proper consideration, in selecting forms of development, to the values and needs expressed by the populations concerned

Distribution of protected areas by bioclimatic domain

(km²)

Sugar maple-bitternut hickory domain	925
Sugar maple-basswood domain	1,006
Sugar maple-yellow birch domain	4,580
Balsam fir-yellow birch domain	4,917
Balsam fir-white birch domain	7,234
Spruce-moss domain	33,945
Spruce-lichen domain	18,245
Forest tundra domain	15,539
Shrub arctic tundra domain	7,753
Herbaceous arctic tundra domain	1,624
Waters of the St. Lawrence River, James Bay, Hudson Bay, Ungava Bay and Hudson Strait	4,314
Total	100,082

Plant species designated as threatened or vulnerable

Small White Leek
Pullyroot
Green dragon
Butterfly milkweed
Pod-fern
White wood-aster
American alpine lady fern
False hop sedge
Late coral-root
Broom crowberry
Ram's-head lady's slipper
Wall rue
False mermaid-weed
Dwarf huckleberry
American ginseng
Woodland sunflower
Lizard's tail
Slender muhly
Softhair marbleseed
Rock elm
Pitch pine
Broad beech fern
May apple
Eastern jacob's-ladder
Pinedrops
Douglas' knotweed
Round-leaf groundsel
Fragrant sumac
Bog fern
Marsh valerian
Blunt-lobed cliff fern

Animal species likely to be designated as threatened or vulnerable

Fish	2
Amphibians	5
Turtles	2
Reptiles	3
Birds	6
Mammals	12

5 Forest Management Highlights

05.00.01

Allowable annual cut in Québec's forest (m³, 000s)

	March 31, 2009
Allowable annual cut - public forests (common areas) (softwoods : 69.2 %, hardwoods : 30.8 %)	32,196.5
Allowable annual cut - private forests (regional agencies) (softwoods : 46.4 %, hardwoods : 53.6 %)	11,968.8
Current volumes (softwoods : 36.9 %, hardwoods : 63.1 %)	651.6
Total	44,816.9

Surface areas considered in calculating the allowable annual cut in Québec (ha, 000s)

	March 31, 2009
Productive public forests ¹ - TSFMAs and FMAs	27,696.8
- FMCs	1,373.6
Productive private forests ¹ (regional agencies)	6,624.6
Total	35,695.0

1. Grades between 0 % and 40 %.

Volume of timber allocated in Québec's public forests (m³, 000s)

	March 31, 2009
Timber supply and forest management agreements (TSFMAs) and Forest management agreements (FMAs)	27,951.8
Forest management contracts (FMCs)	845.3

Number of common areas and timber supply and forest management agreements

	March 31, 2009
Management units	74
Timber supply and forest management agreements (TSFMAs) and Forest management agreements (FMAs)	187
Forest management contracts (FMCs)	89

Volume of timber harvested in Québec in 2008-2009 (m³, 000s)

Public forests	17,237p
Private forests (estimate) ¹	6,149p
- Volumes marketed by syndicates and marketing boards	3,573
Total	23,386
Volumes harvested/allowable annual cut	
- Softwoods	58.2 %
- Hardwoods	43.8 %
Total²	53.0 %

1. Including approximately 2.0 million m³ of firewood.

2. Allowable annual cut (public and private forests), all species combined.

Forest biomass available in Québec 2007-2008 (BDMT, 000s)

	Softwoods	Hardwoods	Total
Public forests	1,399	2,284	3,683
Private forests	759	2,007	2,766
Total	2,158	4,291	6,449

Size of cutting areas in Québec

2008-2009 (ha, 000s)

Public forests	140.7
Private forests (estimate)	60.0
Total	200.7
Total size of cutting areas/productive forest area¹	0.56 %

1. Total area of public and private forests considered in calculating the allowable annual cut.

Market value of standing trees (public forests, all species combined), based on the mean provincial unit rate

	(\$/m ³)
2006-2007	10.42
2007-2008	8.54
2008-2009	8.04

Relative share of transportation methods used for Québec's lumber exports

	2006-2007	2007-2008	2008-2009p
Rail	33.1 %	34.5 %	34.3 %
Truck	63.5 %	57.7 %	60.3 %
Ship	3.4 %	7.8 %	5.4 %
Total	100 %	100 %	100 %

Network of permanent forest roads in Québec in 2005-2006

Length (km)	16,700e
Bridges (no.)	590e

Québec's production of seedlings for reforestation

	2007-2008	2008-2009
Cones harvested (hl)	1,536.7p	1,086.9p
Area of seed tree orchards (ha)	1,332.5p	1,357.3p
Seedlings produced (000s)	153,857.0p	156,890.0p
- MRNF nurseries	45,487.0p	46,117.0p
- Privately owned nurseries	108,370.0p	110,773.0p

Reforestation in Québec

	(seedlings, 000s)	(ha, 000s)
Public forests		
2006-2007r	114,587	79.5
2007-2008r	112,312	69.5
2008-2009p	144,694	65.8
Private forests		
2006-2007r	20,317	9.3
2007-2008r	18,676	8.6
2008-2009p	18,225	8.3
Total		
2006-2007r	134,904	88.8
2007-2008r	130,988	78.1
2008-2009p	162,919	74.1

5 Forest Management Highlights (cont'd)

05.00.01

Site preparation in Québec's forests (ha, 000s)

Public forests	2006-2007r	67.8
	2007-2008r	70.7
	2008-2009p	73.8
Private forests	2006-2007r	7.6
	2007-2008r	7.6
	2008-2009p	6.9
Total	2006-2007r	75.4
	2007-2008r	78.4
	2008-2009p	80.7

Noncommercial silvicultural treatments carried out in Québec ¹ (ha, 000s)

Public forests	2006-2007r	99.7
	2007-2008r	84.7
	2008-2009p	73.9
Private forests	2006-2007r	18.9
	2007-2008r	18.7
	2008-2009p	19.1
Total	2006-2007r	118.5
	2007-2008r	103.3
	2008-2009p	93.0

Commercial silvicultural treatments carried out in Québec ¹ (ha, 000s)

Public forests	2006-2007r	208.1
	2007-2008r	171.2
	2008-2009p	140.7
Private forests	2006-2007r	14.3
	2007-2008r	14.5
	2008-2009p	12.2
Total	2006-2007r	222.5
	2007-2008r	185.8
	2008-2009p	152.9

Silvicultural treatments planned in Québec forests to achieve fixed yields (ha, 000s/year)

Management units	540.6
Regional agencies for private forest development ²	67.4

1. Traitements sylvicoles prévus dans les forêts publiques (2008-2009).

2. Traitements sylvicoles prévus dans les forêts privées (2000-2008).

Silvicultural treatments carried out in Québec (ha, 000s)

Public forests	2005-2006r	460.4
	2006-2007r	455.8
	2007-2008r	396.8
Private forests	2008-2009p	354.1
	2005-2006r	49.0
	2006-2007r	50.0
Total	2007-2008r	49.4
	2008-2009p	46.5
	2005-2006r	509.4
Total	2006-2007r	505.8
	2007-2008r	446.1
	2008-2009p	400.6

5 Forest management

Allowable annual cut

The allowable annual cut was calculated for public forests (areas covered by common areas) (35.9 million ha) and for small and large private holdings (6.6 million ha).

Allowable annual cut by administrative region¹ on March 31, 2009 (public forests - common areas) (m³)

05.01.01

Administrative regions	Public forests (Common areas)					Forest reserves ²					Total
	Fir, spruce, jack pine, larch	Other softwoods	Poplars	Other hardwoods	Subtotal	Fir, spruce, jack pine, larch	Other softwoods	Poplars	Other hardwoods	Subtotal	
01 Bas-Saint-Laurent	604,708	32,621	91,266	199,218	927,813	-	-	-	-	-	-
02 Saguenay—Lac-Saint-Jean	6,016,270	2,730	523,250	1,030,842	7,573,092	-	-	-	-	-	-
03 Capitale-Nationale	612,075	3,746	77,698	273,030	966,549	-	-	-	-	-	-
04 Mauricie	2,265,359	37,427	482,836	1,023,635	3,809,257	-	-	-	-	-	-
05 Estrie	29,784	1,241	5,402	31,536	67,963	-	-	-	-	-	-
06 Montréal	-	-	-	-	-	-	-	-	-	-	-
07 Outaouais	639,507	293,146	235,663	1,117,648	2,285,964	-	-	-	-	-	-
08 Abitibi-Témiscamingue	2,320,095	336,552	545,233	1,101,758	4,303,638	-	-	-	-	-	-
09 Côte-Nord	3,384,586	-	162,381	254,065	3,801,032	-	-	-	-	-	-
10 Nord-du-Québec	3,589,671	61	396,114	160,906	4,146,752	-	-	-	-	-	-
11 Gaspésie—Îles-de-la-Madeleine	1,148,292	23,779	134,334	227,082	1,533,487	-	-	-	-	-	-
12 Chaudière-Appalaches	140,100	6,525	21,350	49,000	216,975	-	-	-	-	-	-
13 Laval	-	-	-	-	-	-	-	-	-	-	-
14 Lanaudière	419,829	21,941	136,874	370,053	948,697	-	-	-	-	-	-
15 Laurentides	602,608	60,497	118,351	831,963	1,613,419	-	-	-	-	-	-
16 Montérégie	-	-	-	-	-	-	-	-	-	-	-
17 Centre-du-Québec	816	34	148	864	1,862	-	-	-	-	-	-
Total	21,773,700	820,300	2,930,900	6,671,600	32,196,500	-	-	-	-	-	-

Allowable annual cut³ by administrative region⁴ on March 31, 2009 (private forests) (m³)

Administrative regions	Allowable annual cut					Current volumes					Total
	Fir, spruce, jack pine, larch	Other softwoods	Poplars	Other hardwoods	Subtotal	Fir, spruce, jack pine, larch	Other softwoods	Poplars	Other hardwoods	Subtotal	
01 Bas-Saint-Laurent	808,550	60,700	373,900	316,200	1,559,350	25,800	28,300	172,100	92,800	319,000	1,878,350
02 Saguenay—Lac-Saint-Jean	303,800	3,600	191,600	81,800	580,800	-	-	-	-	-	580,800
03 Capitale-Nationale	393,000	38,500	158,400	370,000	959,900	-	-	-	-	-	959,900
04 Mauricie	457,700	33,900	71,200	253,900	816,700	-	-	-	-	-	816,700
05 Estrie	494,100	132,200	127,500	555,000	1,308,800	6,000	30,400	-	19,600	56,000	1,364,800
06 Montréal	-	-	-	-	-	-	-	-	-	-	-
07 Outaouais	172,600	220,600	269,000	557,500	1,219,700	-	-	-	-	-	1,219,700
08 Abitibi-Témiscamingue	233,400	15,700	521,400	74,100	844,600	-	-	-	-	-	844,600
09 Côte-Nord	113,300	1,300	51,900	31,600	198,100	-	-	-	-	-	198,100
10 Nord-du-Québec	-	-	-	-	-	-	-	-	-	-	-
11 Gaspésie—Îles-de-la-Madeleine	259,100	19,800	110,500	136,200	525,600	19,400	28,600	29,600	35,600	113,200	638,800
12 Chaudière-Appalaches	913,400	165,100	169,700	714,700	1,962,900	8,000	45,000	12,000	-	65,000	2,027,900
13 Laval	-	-	-	-	-	-	-	-	-	-	-
14 Lanaudière	88,700	28,300	38,100	158,700	313,800	-	-	-	-	-	313,800
15 Laurentides	211,300	73,600	140,400	427,000	852,300	4,600	44,300	14,100	35,400	98,400	950,700
16 Montérégie	36,300	66,200	30,000	283,900	416,400	-	-	-	-	-	416,400
17 Centre-du-Québec	154,400	57,800	58,000	139,600	409,800	-	-	-	-	-	409,800
Total	4,639,650	917,300	2,311,600	4,100,200	11,968,750	63,800	176,600	227,800	183,400	651,600	12,620,350

1. Volumes are distributed proportionally to the size of common areas located in the region.

2. Data not available at this time.

3. Established by the regional agencies for private forests development as part of the PPDF.

4. Includes small and large private forests and excludes Category 1 lands.

5 Forest management

Allowable annual cut (cont'd)

Breakdown of allowable annual cut by species in 2008-2009

05.01.02

Public forests (allowable annual cut in common areas)

Hardwoods 29.8 %

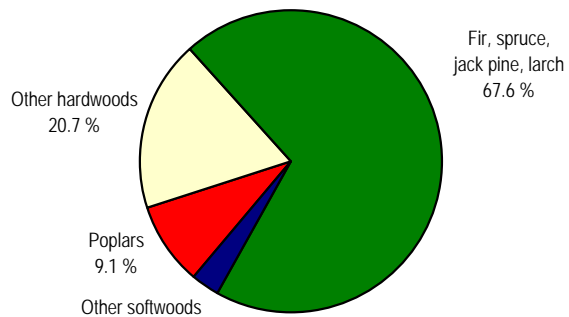

Softwoods 70.2 %

05.01.03

Private forests (allowable annual cut in agency territories)

Hardwoods 53.6 %

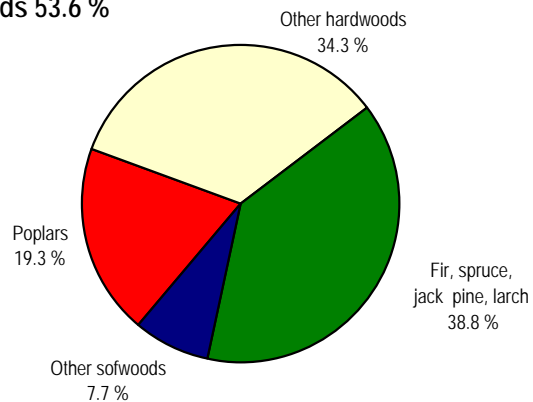

Softwoods 46.4 %

5 Forest Management

Allowable annual cut (cont'd)

Allowable annual cut/volumes allocated (common areas)/volumes harvested (public forests)

By species group, 2007-2008

(Mm³)

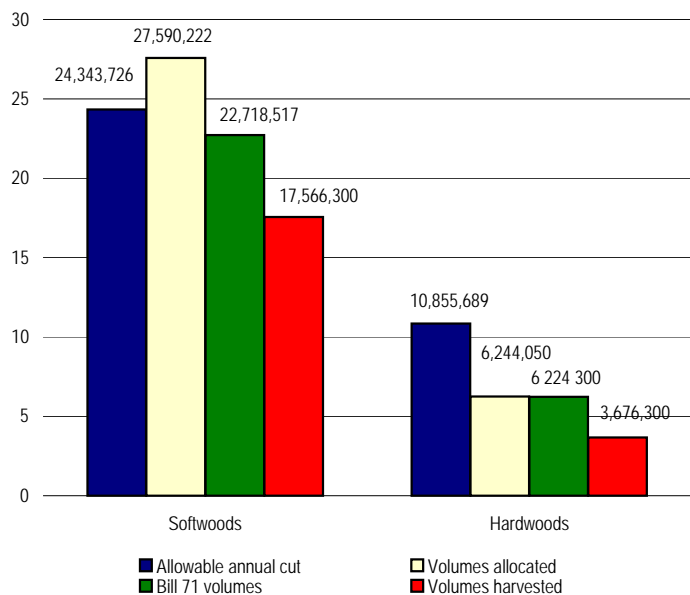

By species group, 2008-2009

(Mm³)

05.01.11

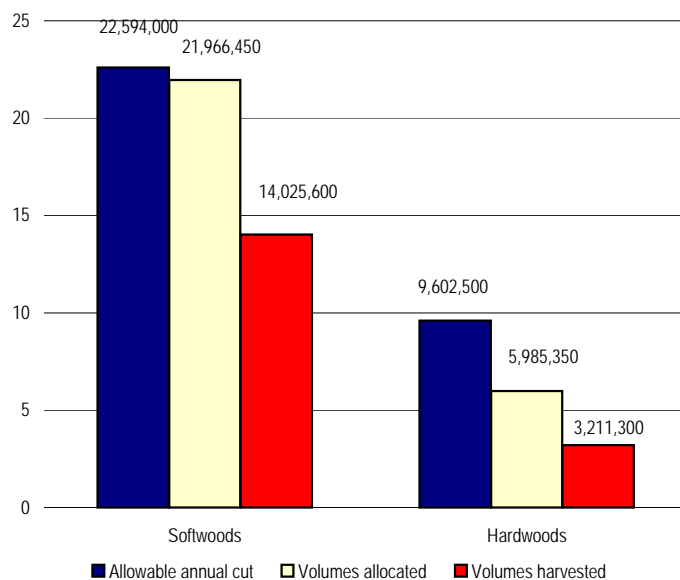

Allowable annual cut/volumes harvested¹ (private forests)

By species group, 2007-2008

(Mm³)

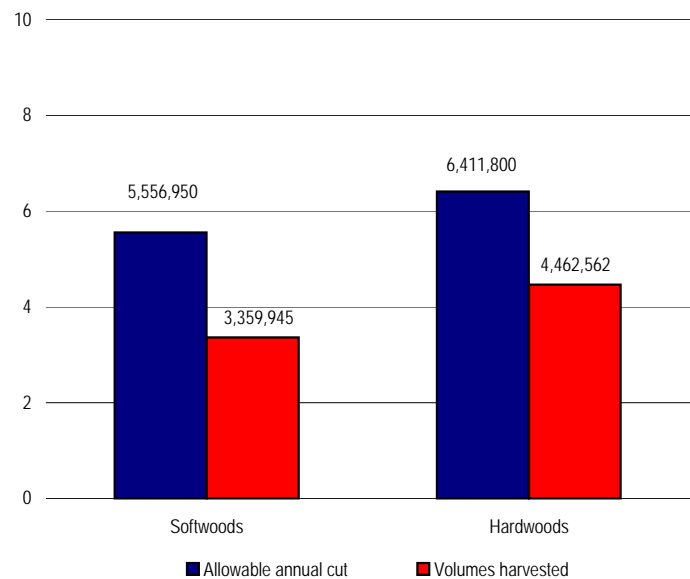

Allowable annual cut/volumes harvested¹ (private forests)

By species group, 2008-2009

(Mm³)

05.01.12

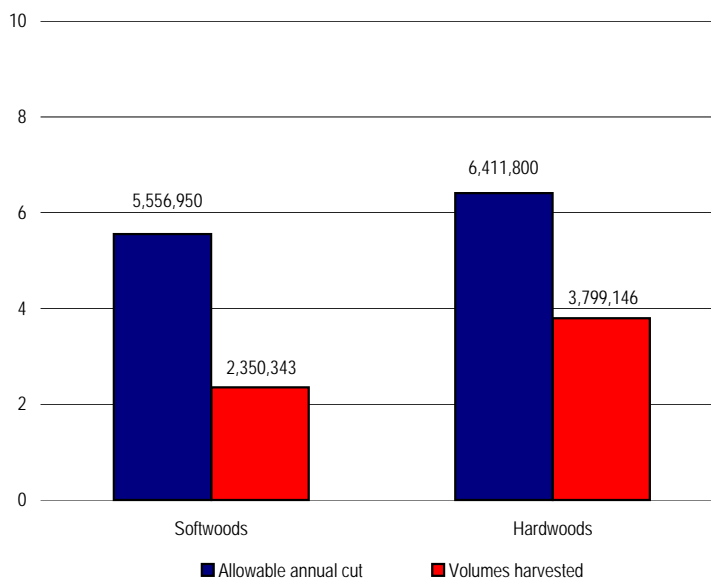

1. Including an estimated volume of firewood (1.9 million m³ of hardwoods).

1. Including an estimated volume of firewood (1.9 million m³ of hardwoods).

5 Forest management

Harvest

Volume of timber harvested in public and private forests

A) By tenure and species group

05.02.01

	2004-2005		2005-2006		2006-2007		2007-2008		2008-2009	
	Total		Total		Total		Total		Total	
	('000 m ³)	(%)	('000 m ³)	(%)	('000 m ³)	(%)	('000 m ³)	(%)	('000 m ³)	(%)
Total	43,332	100	38,616	100	33,013	100	29,065p	100	23,386p	100
Softwoods	32,125	74	28,883	75	24,341	74	20,926p	72	16,376p	70
Hardwoods	11,207	26	9,734	25	8,672	26	8,139p	28	7,010p	30
Québec public lands¹	34,273	100	29,537	100	24,254	100	21,243p	100	17,237p	100
Softwoods	28,084	82	24,571	83	20,234	83	17,566p	83	14,026p	81
Hardwoods	6,189	18	4,967	17	4,020	17	3,676p	17	3,211p	19
Private holdings²	9,059	100	9,079	100	8,758	100	7,823	100	6,149	100
Softwoods	4,041	45	4,312	47	4,107	47	3,360	43	2,350	38
Hardwoods	5,018	55	4,767	53	4,651	53	4,463	57	3,799	62

1. Volume of timber harvested and actually measured in public forests, not including small volumes harvested for specific purposes (public utility works, mining activities wildlife and leisure developments, etc.).

2. Estimated volume harvested in private forests by individual producers or producers' groups, including chips and firewood (approx. 1.9 million m³), but excluding small volumes of roundwood harvested for export.

5 Forest management

Harvest (cont'd)

Volume of timber harvested in public and private forests (cont'd)

B) By administrative region (m³, 000s)

2006-2007

05.02.02

Administrative regions	Public forests ¹						Private forests ²					
	Fir, spruce, jack pine, larch	Other softwoods	Total softwoods	Poplars	Other hardwoods	Total hardwoods	Fir, spruce, jack pine, larch	Other softwoods	Total softwoods	Poplars	Other hardwoods	Total hardwoods
01 Bas-Saint-Laurent	679.0p	20.1p	699.1p	100.7p	159.8p	260.6p	510.8p	25.2p	536.0p	373.8p	243.6p	617.4p
02 Saguenay—Lac-Saint-Jean	6,001.5p	0.0p	6,001.5p	250.8p	223.1p	473.9p	408.1p		408.1p	128.5p	51.1p	179.6p
03 Capitale-Nationale	675.1p	1.0p	676.0p	29.7p	84.3p	114.0p	345.5p	15.0p	360.4p	89.9p	224.6p	314.5p
04 Mauricie	1,909.1p	49.7p	1,958.9p	309.4p	328.2p	637.5p	222.6p	13.3p	235.9p	42.8p	154.8p	197.5p
05 Estrie	23.4p	0.6p	24.0p	2.9p	41.4p	44.2p	468.6p	65.9p	534.5p	127.3p	535.3p	662.5p
06 Montréal	-	-	-	-	-	-	-	-	-	-	-	-
07 Outaouais	387.8p	177.3p	565.1p	195.7p	335.2p	530.9p	189.1p	75.4p	264.5p	245.4p	387.3p	632.7p
08 Abitibi-Témiscamingue	1,937.4p	139.5p	2,076.9p	481.9p	316.8p	798.6p	156.8p	0.3p	157.0p	272.4p	41.8p	314.2p
09 Côte-Nord	3,367.9p		3,367.9p	37.2p	19.1p	56.3p	7.1p	-	7.1p	7.2p	15.8p	23.0p
10 Nord-du-Québec	2,944.1p	0.0p	2,944.1p	321.8p	3.3p	325.1p	40.6p	-	40.6p	-	-	-
11 Gaspésie—Îles-de-la-Madeleine	1,004.8p	1.5p	1,006.4p	75.8p	57.0p	132.8p	311.1p	4.0p	315.1p	65.3p	58.2p	123.5p
12 Chaudière-Appalaches	121.4p	10.5p	131.8p	21.1p	26.5p	47.6p	777.6p	70.0p	847.6p	136.1p	398.5p	534.7p
13 Laval	-	-	-	-	-	-	-	-	-	-	-	-
14 Lanaudière	365.5p	7.2p	372.7p	70.7p	130.1p	200.8p	55.9p	16.5p	72.4p	22.8p	140.2p	162.9p
15 Laurentides	389.9p	19.7p	409.5p	45.3p	352.6p	397.9p	87.9p	23.0p	110.9p	103.0p	331.0p	434.0p
16 Montérégie	-	-	-	-	-	-	6.1p	6.7p	12.9p	18.1p	233.0p	251.1p
17 Centre-du-Québec	-	-	-	-	-	-	179.2p	24.8p	204.0p	30.4p	173.1p	203.5p
Total	19,806.9p	427.1p	20,233.9p	1,942.8p	2,077.4p	4,020.2p	3,767.0p	340.1p	4,107.1p	1,663.0p	2,988.3p	4,651.4p

1. Volume of timber harvested and actually measured in public forests, not including small volumes harvested for specific purposes (public utility works, mining activities, wildlife and leisure developments, etc.).

2. Estimated volume harvested in private forests by individual producers or producers' groups, including chips and firewood (approx. 1.9 million m³), but excluding small volumes of roundwood harvested for export and volumes delivered to mills of 2,000 m³ and less.

2007-2008

05.02.03

Administrative regions	Public forests ¹						Private forests ²					
	Fir, spruce, jack pine, larch	Other softwoods	Total softwoods	Poplars	Other hardwoods	Total hardwoods	Fir, spruce, jack pine, larch	Other softwoods	Total softwoods	Poplars	Other hardwoods	Total hardwoods
01 Bas-Saint-Laurent	656.8p	23.1p	679.9p	102.3p	156.3p	258.6p	332.7p	9.9p	342.6p	301.5p	150.2p	451.7p
02 Saguenay—Lac-Saint-Jean	5,595.7p	0.1p	5,595.7p	280.9p	284.5p	565.4p	315.4p		315.4p	145.6p	13.6p	159.2p
03 Capitale-Nationale	445.8p	1.5p	447.3p	27.6p	71.4p	99.0p	340.9p	16.8p	357.7p	59.6p	102.0p	161.6p
04 Mauricie	2,043.0p	23.8p	2,066.9p	207.1p	337.9p	545.0p	136.3p	10.6p	146.9p	17.9p	72.9p	90.8p
05 Estrie	25.1p	0.5p	25.6p	5.9p	29.0p	34.9p	386.9p	49.0p	435.8p	143.6p	317.9p	461.4p
06 Montréal	-	-	-	-	-	-	-	-	-	-	-	-
07 Outaouais	326.1p	131.0p	457.1p	149.6p	486.4p	636.0p	171.5p	55.9p	227.4p	231.3p	197.3p	428.5p
08 Abitibi-Témiscamingue	2,253.6p	71.7p	2,325.2p	366.2p	314.1p	680.3p	197.0p	2.3p	199.2p	237.2p	16.1p	253.4p
09 Côte-Nord	1,827.0p	0.1p	1,827.1p	51.3p	28.0p	79.3p	10.5p	0.0p	10.6p	22.0p	1.1p	23.1p
10 Nord-du-Québec	2,414.5p		2,414.5p	155.1p	1.5p	156.6p						
11 Gaspésie—Îles-de-la-Madeleine	931.3p	2.2p	933.5p	87.5p	64.8p	152.3p	247.0p	2.6p	249.6p	60.9p	31.5p	92.4p
12 Chaudière-Appalaches	122.7p	10.6p	133.3p	21.3p	30.9p	52.3p	639.9p	73.6p	713.6p	114.2p	49.8p	164.1p
13 Laval	-	-	-	-	-	-	-	-	-	-	-	-
14 Lanaudière	222.3p	3.5p	225.8p	18.6p	89.5p	108.1p	38.7p	6.7p	45.5p	12.8p	12.0p	24.8p
15 Laurentides	408.5p	25.8p	434.2p	44.3p	264.0p	308.2p	96.2p	22.8p	119.0p	90.6p	88.7p	179.4p
16 Montérégie	-	-	-	-	-	-	9.0p	6.5p	15.4p	19.5p	22.7p	42.2p
17 Centre-du-Québec	-	-	-	-	0.3p	0.3p	157.1p	24.2p	181.2p	40.6p	36.9p	77.5p
Total	17,272.4p	293.9p	17,566.3p	1,517.6p	2,158.6p	3,676.3p	3,079.1p	280.8p	3,359.9p	1,497.2p	1,112.8p	2,610.1p

1. Volume of timber harvested and actually measured in public forests, not including small volumes harvested for specific purposes (public utility works, mining activities, wildlife and leisure developments, etc.).

2. Estimated volume harvested in private forests by individual producers or producers' groups, including chips and firewood (approx. 1.9 million m³), but excluding small volumes of roundwood harvested for export and volumes delivered to mills of 2,000 m³ and less.

5 Forest management

Harvest (cont'd)

Volume of timber harvested in public and private forests (cont'd)

B) By administrative region (m³, 000s) (cont'd)

2008-2009

05.02.04

	Public forests ¹						Private forests ²					
	Fir, spruce, jack pine, larch	Other softwoods	Total softwoods	Poplars	Other hardwoods	Total hardwoods	Fir, spruce, jack pine, larch	Other softwoods	Total softwoods	Poplars	Other hardwoods	Total hardwoods
Administrative regions												
01 Bas-Saint-Laurent	391.1p	16.7p	407.8p	104.1p	146.5p	250.7p	302.2p	6.3p	308.5p	243.1p	219.5p	462.6p
02 Saguenay—Lac-Saint-Jean	4,268.3p	0.0p	4,268.4p	30.8p	229.4p	260.1p	122.7p	0.1p	122.8p	47.4p	43.3p	90.6p
03 Capitale-Nationale	463.4p	1.5p	464.9p	29.2p	92.1p	121.3p	215.0p	14.1p	229.1p	42.8p	219.9p	262.7p
04 Mauricie	1,774.8p	18.5p	1,793.3p	229.8p	520.3p	750.1p	86.1p	8.4p	94.4p	12.8p	118.1p	130.9p
05 Estrie	14.9p	0.2p	15.1p	2.1p	20.6p	22.7p	294.3p	27.7p	322.0p	147.6p	540.0p	687.6p
06 Montréal	-	-	-	-	-	-	-	-	-	-	-	-
07 Outaouais	334.6p	51.7p	386.3p	118.5p	274.4p	392.9p	120.3p	42.7p	163.0p	161.4p	354.1p	515.5p
08 Abitibi-Témiscamingue	1,320.7p	45.9p	1,366.6p	290.4p	185.7p	476.0p	38.1p	4.2p	42.3p	100.0p	33.2p	133.2p
09 Côte-Nord	1,680.5p	-	1,680.5p	60.5p	29.0p	89.6p	2.9p	1.0p	3.9p	12.3p	16.4p	28.7p
10 Nord-du-Québec	2,306.9p	-	2,306.9p	134.0p	1.1p	135.2p	-	-	-	-	-	-
11 Gaspésie—Îles-de-la-Madeleine	559.4p	0.6p	560.0p	56.7p	45.1p	101.8p	178.2p	0.5p	178.7p	48.3p	56.5p	104.8p
12 Chaudière-Appalaches	135.8p	5.7p	141.5p	22.7p	37.6p	60.3p	559.4p	35.1p	594.6p	91.0p	379.2p	470.1p
13 Laval	-	-	-	-	-	-	-	-	-	-	-	-
14 Lanaudière	198.9p	6.0p	204.9p	46.3p	119.6p	165.9p	27.1p	6.8p	33.9p	11.9p	124.4p	136.3p
15 Laurentides	407.9p	21.8p	429.7p	30.8p	353.8p	384.6p	27.8p	12.6p	40.4p	33.0p	281.6p	314.6p
16 Montérégie	-	-	-	0.0p	0.2p	0.2p	3.8p	15.1p	18.9p	16.3p	227.0p	243.2p
17 Centre-du-Québec	-	-	-	-	-	-	144.5p	21.4p	165.9p	40.3p	178.0p	218.3p
Total	13,857.2p	168.4p	14,025.6p	1,155.8p	2,055.5p	3,211.3p	2,122.4p	196.0p	2,318.4p	1,008.2p	2,791.0p	3,799.1p

1. Volume of timber harvested and actually measured in public forests, not including small volumes harvested for specific purposes (public utility works, mining activities, wildlife and leisure developments, etc.).

2. Estimated volume harvested in private forests by individual producers or producers' groups, including chips and firewood (approx. 1.9 million m³), but excluding small volumes of roundwood harvested for export and volumes delivered to mills of 2,000 m³ and less.

5 Forest management

Forest dues

Market value of standing timber in public forests, by quality and mean provincial unit rates, 2005-2006 and 2006-2007 (\$/m³)

05.03.07

Species group	Quality ²	Fiscal year (Period) ¹									
		2005-2006					2006-2007				
		1 ^{re} pér.	2 ^e pér.	3 ^e pér.	4 ^e pér.	Mean	1 ^{re} pér.	2 ^e pér.	3 ^e pér.	4 ^e pér.	Mean
Jack pine	F (pole)	18.44	18.44	18.49	18.44	18.45	15.74	15.72	16.27	16.83	16.14
Fir, spruce, jack pine, larch	B (saw timber, pulp)	14.40	14.39	13.92	13.44	14.04	12.65	12.37	11.79	10.98	11.95
White pine	G (saw timber)	27.48	27.32	27.22	26.29	27.08	25.26	25.18	25.18	25.21	25.21
	H (saw timber)	14.19	14.11	14.06	13.58	13.98	12.74	12.70	12.70	12.71	12.71
	I (saw timber)	11.09	11.03	10.99	10.61	10.93	9.82	9.79	9.79	9.80	9.80
Red pine	F (pole)	24.62	24.62	24.69	24.62	24.64	19.24	19.23	19.89	20.58	19.74
	G (saw timber)	19.98	19.86	19.78	19.11	19.68	14.58	14.53	14.53	14.55	14.55
	H (saw timber)	10.17	10.11	10.07	9.73	10.02	8.00	7.97	7.97	7.98	7.98
	I (saw timber)	8.32	8.27	8.24	7.96	8.20	6.52	6.50	6.50	6.51	6.51
Hemlock, thuja	B (saw timber)	3.43	3.40	3.27	3.15	3.31	3.25	3.16	2.97	2.70	3.02
White pine, red pine, hemlock, thuja	C (pulp)	2.06	2.05	1.97	1.89	1.99	1.75	1.70	1.59	1.45	1.62
Oak, cherry, walnut, hickory	A (peeling)	60.69	61.22	60.95	60.03	60.72	60.03	59.71	59.27	59.33	59.58
	B (saw timber)	33.78	33.22	33.22	33.12	33.34	30.37	30.34	30.28	30.31	30.32
	C (saw timber)	13.19	12.98	12.98	12.93	13.02	12.48	12.47	12.44	12.46	12.46
Yellow birch, ash, basswood, elm	A (peeling)	52.85	53.31	53.08	52.27	52.88	52.41	52.13	51.74	51.80	52.02
	B (saw timber)	23.10	22.72	22.72	22.65	22.80	22.68	22.66	22.61	22.63	22.65
	C (saw timber)	8.74	8.60	8.60	8.57	8.63	8.57	8.56	8.54	8.55	8.55
White birch	A (peeling)	37.74	38.07	37.90	37.33	37.76	32.70	32.53	32.29	32.32	32.46
	B (saw timber)	13.19	12.97	12.97	12.93	13.02	12.87	12.85	12.83	12.84	12.85
	C (saw timber)	4.80	4.72	4.72	4.70	4.74	4.85	4.85	4.84	4.84	4.85
Sugar maple	B (saw timber)	27.25	27.37	27.17	26.86	27.16	24.96	24.83	24.48	24.51	24.70
	C (saw timber)	6.43	6.46	6.41	6.34	6.41	5.59	5.56	5.48	5.49	5.53
Other hardwoods	B (saw timber)	10.48	10.30	10.30	10.27	10.34	9.58	9.57	9.55	9.56	9.56
	C (saw timber)	4.61	4.54	4.54	4.52	4.55	4.20	4.19	4.18	4.19	4.19
Poplars	B (saw timber, pulp)	6.70	6.57	5.46	6.70	6.36	4.68	4.13	3.44	3.17	3.86
All hardwoods (except poplars)	D, E (pulp)	3.24	3.21	3.06	3.21	3.18	2.55	2.48	2.40	2.38	2.45
All species	All qualities	12.99	12.96	12.48	12.18	12.65	11.04	10.77	10.25	9.60	10.42

1. First period, from April 1 to June 30; second period, from July 1 to September 30; third period, from October 1 to December 31; fourth period, from January 1 to March 31

2. The letters A, B, C, D, E, F, G, H and I correspond to the quality assigned during wood grading based on species, diameter, length, and imperfections observed on the trunk and crosscuts

5 Forest management

Forest dues (cont'd)

Market value of standing timber in public forests,
by quality and mean provincial unit rates, 2007-2008 and 2008-2009 (\$/m³)

05.03.08

Species group	Quality ²	Fiscal year (Period) ¹					Fiscal year (Period) ¹				
		2007-2008					2008-2009				
		1 ^{re} pér.	2 ^e pér.	3 ^e pér.	4 ^e pér.	Moy.	1 ^{re} pér.	2 ^e pér.	3 ^e pér.	4 ^e pér.	Moy.
Jack pine	F (pole)	20.25	20.33	20.63	20.61	20.45	21.31	21.35	21.27	21.37	21.32
Fir, spruce, jack pine, larch	B (saw timber, pulp)	10.08	9.83	10.21	9.39	9.88	9.12	9.00	9.41	9.93	9.36
White pine	G (saw timber)	24.25	23.49	21.67	20.38	22.45	20.26	19.92	20.84	22.84	20.97
	H (saw timber)	8.63	8.36	7.71	7.25	7.99	7.08	6.96	7.28	7.98	7.32
	I (saw timber)	6.03	5.84	5.39	5.07	5.58	4.64	4.56	4.77	5.23	4.80
Red pine	F (pole)	25.76	25.86	26.24	26.22	26.02	26.49	26.53	26.44	26.56	26.50
	G (saw timber)	14.58	14.13	13.03	12.26	13.50	13.69	13.46	14.08	15.43	14.16
	H (saw timber)	4.79	4.64	4.28	4.03	4.44	4.99	4.91	5.14	5.63	5.17
	I (saw timber)	3.30	3.20	2.95	2.77	3.05	2.53	2.48	2.60	2.85	2.61
Hemlock, thuja	B (saw timber)	2.72	2.65	2.76	2.54	2.67	1.65	1.63	1.70	1.79	1.69
White pine, red pine, hemlock, thuja	C (pulp)	1.57	1.53	1.59	1.46	1.53	1.36	1.34	1.40	1.48	1.39
Oak, cherry, walnut, hickory	A (peeling)	57.84	57.30	55.92	54.84	56.48	51.33	51.33	51.66	53.76	52.02
	B (saw timber)	31.29	28.47	26.84	26.46	28.26	20.54	20.32	20.25	20.90	20.50
	C (saw timber)	12.32	11.21	10.57	10.42	11.13	5.59	5.53	5.51	5.69	5.58
Yellow birch, ash, basswood, elm	A (peeling)	53.40	52.90	51.62	50.63	52.14	45.61	45.61	45.90	47.76	46.22
	B (saw timber)	21.50	19.57	18.44	18.18	19.42	15.72	15.55	15.49	15.99	15.69
	C (saw timber)	7.29	6.63	6.25	6.16	6.58	3.39	3.35	3.34	3.45	3.38
White birch	A (peeling)	38.16	37.81	36.90	36.18	37.26	31.98	31.98	32.19	33.50	32.41
	B (saw timber)	9.95	9.05	8.53	8.41	8.99	6.10	6.04	6.01	6.21	6.09
	C (saw timber)	2.22	2.02	1.91	1.88	2.01	0.70	0.69	0.69	0.71	0.70
Sugar maple	B (saw timber)	23.67	21.83	20.70	19.92	21.53	17.89	17.74	17.96	18.56	18.04
	C (saw timber)	4.22	3.89	3.69	3.55	3.83	3.67	3.64	3.68	3.81	3.70
Other hardwoods	B (saw timber)	10.00	9.10	8.58	8.45	9.03	8.09	8.00	7.97	8.23	8.07
	C (saw timber)	3.92	3.57	3.37	3.32	3.54	2.04	2.02	2.01	2.07	2.03
Poplars	B (saw timber, pulp)	1.58	1.54	1.72	1.53	1.59	1.39	1.49	1.69	1.69	1.56
All hardwoods (except poplars)	D, E (pulp)	0.65	0.61	0.59	0.58	0.61	0.41	0.42	0.43	0.44	0.43
All species	All qualities	8.74	8.50	8.81	8.11	8.54	7.83	7.74	8.09	8.52	8.04

1. First period, from April 1 to June 30; second period, from July 1 to September 30; third period, from October 1 to December 31; fourth period, from January 1 to March 31

2. The letters A, B, C, D, E, F, G, H and I correspond to the quality assigned during wood grading based on species, diameter, length, and imperfections observed on the trunk and crosscuts

5 Forest management

Seedling production

Seedling production (000s) by administrative region¹ and producer category

05.05.05

Administrative regions	Producers	2004-2005			2005-2006			2006-2007			2007-2008			2008-2009		
		Bareroot	Container	Total	Bareroot	Container	Total	Bareroot	Container	Total	Bareroot	Container	Total	Bareroot	Container	Total
01 Bas-Saint-Laurent	PUN ²	8,000	7,668	15,668	6,811	7,418	14,229	6,290	8,298	14,588	5,319	8,573	13,892	4,043	8,255	12,298
	P&FC ³	-	8,788	8,788	-	5,639	5,639	-	4,672	4,672	-	3,891	3,891	-	4,175	4,175
	Total	8,000	16,456	24,456	6,811	13,057	19,868	6,290	12,970	19,260	5,319	12,464	17,783	4,043	12,430	16,473
02 Saguenay—Lac-Saint-Jean	PUN	2,680	2,449	5,129	2,505	3,175	5,680	2,243	5,092	7,335	1,606	10,432	12,038	916	16,775	17,691
	P&FC	-	17,284	17,284	-	19,577	19,577	-	23,608	23,608	-	33,280	33,280	-	34,106	34,106
	Total	2,680	19,733	22,413	2,505	22,752	25,257	2,243	28,700	30,943	1,606	43,712	45,318	916	50,881	51,797
03 Capitale-Nationale	PUN	-	-	-	-	-	-	-	-	-	-	-	-	-	-	-
	P&FC	-	4,917	4,917	-	5,347	5,347	-	6,591	6,591	-	2,731	2,731	-	4,443	4,443
	Total	-	4,917	4,917	-	5,347	5,347	-	6,591	6,591	-	2,731	2,731	-	4,443	4,443
04 Mauricie et 17 Centre-du-Québec	PUN	1,910	2,007	3,917	1,950	2,691	4,641	1,947	2,152	4,099	1,561	2,554	4,115	764	2,424	3,188
	P&FC	-	18,640	18,640	-	11,174	11,174	-	13,835	13,835	-	13,420	13,420	-	15,695	15,695
	Total	1,910	20,647	22,557	1,950	13,865	15,815	1,947	15,987	17,934	1,561	15,974	17,535	764	18,119	18,883
05 Estrie	PUN	-	-	-	-	-	-	-	-	-	-	-	-	-	-	-
	P&FC	-	-	-	-	-	-	-	-	-	-	-	-	-	-	-
	Total	-	-	-	-	-	-	-	-	-	-	-	-	-	-	-
07 Outaouais	PUN	-	-	-	-	-	-	-	-	-	-	-	-	-	-	-
	P&FC	-	3,719	3,719	-	2,860	2,860	-	3,214	3,214	-	2,856	2,856	-	3,794	3,794
	Total	-	3,719	3,719	-	2,860	2,860	-	3,214	3,214	-	2,856	2,856	-	3,794	3,794
08 Abitibi-Témiscamingue	PUN	1,038	4,354	5,392	925	3,812	4,737	612	7,019	7,631	891	8,655	9,546	221	8,150	8,371
	P&FC	-	27,294	27,294	-	25,350	25,350	-	38,927	38,927	-	25,820	25,820	-	22,187	22,187
	Total	1,038	31,648	32,686	925	29,162	30,087	612	45,946	46,558	891	34,475	35,366	221	30,337	30,558
09 Côte-Nord	PUN	-	-	-	-	-	-	-	-	-	-	-	-	-	-	-
	P&FC	-	7,285	7,285	-	6,619	6,619	-	10,002	10,002	-	10,542	10,542	-	9,542	9,542
	Total	-	7,285	7,285	-	6,619	6,619	-	10,002	10,002	-	10,542	10,542	-	9,542	9,542
11 Gaspésie—Îles-de-la-Madeleine	PUN	-	-	-	-	-	-	-	-	-	-	-	-	-	-	-
	P&FC	-	2,185	2,185	-	4,508	4,508	-	3,708	3,708	-	4,311	4,311	-	3,955	3,955
	Total	-	2,185	2,185	-	4,508	4,508	-	3,708	3,708	-	4,311	4,311	-	3,955	3,955
12 Chaudière-Appalaches	PUN	-	-	-	-	-	-	-	-	-	-	-	-	-	-	-
	P&FC	-	4,083	4,083	-	1,535	1,535	-	1,663	1,663	-	2,355	2,355	-	2,387	2,387
	Total	-	4,083	4,083	-	1,535	1,535	-	1,663	1,663	-	2,355	2,355	-	2,387	2,387
14 Lanaudière	PUN	2,604	2,922	5,526	2,344	2,715	5,059	1,782	2,946	4,728	1,839	4,057	5,896	1,483	3,086	4,569
	P&FC	-	-	-	-	-	-	-	-	-	-	-	-	-	-	-
	Total	2,604	2,922	5,526	2,344	2,715	5,059	1,782	2,946	4,728	1,839	4,057	5,896	1,483	3,086	4,569
15 Laurentides	PUN	-	-	-	-	-	-	-	-	-	-	-	-	-	-	-
	P&FC	-	6,168	6,168	-	10,992	10,992	-	12,180	12,180	-	9,164	9,164	-	10,489	10,489
	Total	-	6,168	6,168	-	10,992	10,992	-	12,180	12,180	-	9,164	9,164	-	10,489	10,489
Total	PUN	16,232	19,400	35,632	14,535	19,811	34,346	12,874	25,507	38,381	11,216	34,271	45,487	7,427	38,690	46,117
	P&FC	-	100,363	100,363	-	93,601	93,601	-	118,400	118,400	-	108,370	108,370	-	110,773	110,773
	Total	16,232	119,763	135,995	14,535	113,412	127,947	12,874	143,907	156,781	11,216	142,641	153,857	7,427	149,463	156,890

1. There is no seedling production in regions 06 (Montréal), 10 (Nord-du-Québec), 13 (Laval) and 16 (Montérégie).

2. PUN: Public nurseries.

3. P&FC: Private producers and forest companies.

5 Forest management

Summary of silvicultural treatments carried out

05.14.01

A) Public forests

Type of treatments	Area (2002-2003) ¹					Area (2003-2004) ¹				
	TSFMA ²		MRNF ³		Total	TSFMA ²		MRNF ³		Total
	(ha)	(%)	(ha)	(%)	(ha)	(ha)	(%)	(ha)	(%)	(ha)
Site preparation										
1) Scarifying	44,323r	100r			44,323r	47,205r	100r			47,205r
2) Clearing	6,444r	100.0			6,444r	5,766r	100.0			5,766r
3) Brushing	336r	41.7	470r	58.3	806r	153r	20.8	582r	79.2	735r
4) Harrowing										
5) Controlled burning										
6) Removal of residual stems	710r	43.1	936r	56.9	1,646r	1,190r	96.2	47r	3.8	1,237r
Total	51,813r	97.4	1,406r	2.6	53,219r	54,314r	98.9	629r	1.1	54,943r
Reforestation and seeding										
1) Planting	(ha)		303r	0.7	40,581r	31,768r	100.0			31,768r
	(Seedlings, million)	72r	99.2	1r	0.8	72r	57r	100.0		57r
2) Reinforcement	(ha)	26,509r	98.4	444r	1.6	26,953r	26,188r	100.0		26,188r
	(Seedlings, million)	28r	96.5	1r	3.5	29r	29r	100.0		29r
3) Enrichment	(ha)	1,623r	100.0		1,623r	2,010r	100.0			2,010r
	(Seedlings, million)	1r	100.0		1r	1r	100.0			1r
4) Regeneration of SBBA ⁴	Natural (ha)									
	Artificial (ha)	7,846r	100.0		7,846r	8,316r	100.0			8,316r
	(Seedlings, million)	9r	100.0		9r	11r	100.0			11r
5) Seeding	(ha)	16r			16r					
Total	(ha)	76,272r	99.0	747r	1.0	77,019r	68,282r	100.0		68,282r
	(Seedlings, million)	109r	98.6	2r	1.4	111r	97r	100.0		97r
Noncommercial treatments										
1) Release (plantations)		15,529r	89.7	1,785r	10.3	17,314r	9,006r	89.6	1,042r	10.4
2) Release (natural regeneration)		3,235r	91.0	321r	9.0	3,556r	2,404r	91.4	227r	8.6
3) Pre-commercial thinning		89,509r	95.7	4,000r	4.3	93,509r	95,192r	96.9	3,058r	3.1
4) Phytosanitary control				318r		318r			1,372r	100.0
5) Fertilization							99r			99r
6) Drainage		3,381r	100.0			3,381r	4,359r	100.0		4,359r
Total		111,654r	94.6	6,424r	5.4	118,078r	111,060r	95.1	5,699r	4.9
Commercial treatments										
1) a) Cutting with protection of regeneration and soils		179,664r	100.0			179,664r	143,642r	100.0		143,642r
b) Merchantable trees		2,689r	100.0			2,689r	903r	100.0		903r
c) Tall regeneration		416r	100.0			416r	549r	100.0		549r
d) With seed reserve		13,731r	100.0			13,731r	2,041r	100.0		2,041r
Subtotal (CPRS)		196,500r	100.0			196,500r	147,136r	100.0		147,136r
2) Block cutting		38,310r	100.0			38,310r	72,381r	100.0		72,381r
3) a) Selection cutting		31,638r	100.0			31,638r	32,643r	100.0		32,643r
b) Pre-selection cutting		11,047r	100.0			11,047r	1,749r	100.0		1,749r
Subtotal		42,684r	100.0			42,684r	34,392r	100.0		34,392r
4) Improvement cutting		538r	100.0			538r	7r	100.0		7r
5) Shelterwood cutting		5,394r	100.0			5,394r	3,977r	100.0		3,977r
6) Commercial thinning		8,087r	97.5	209r	2.5	8,296r	5,592r	97.0	173r	3.0
7) a) Strip cutting		687r	100.0			687r	507r	100.0		507r
b) Patch cutting										
Subtotal		687r	100.0			687r	507r	100.0		507r
8) Harvesting in buffer strips		1,117r	100.0			1,117r	973r	100.0		973r
9) Other methods :										
a) Cutting for reforestation		7,846r	100.0			7,846r	8,316r	100.0		8,316r
b) Clear cutting - SBBA		9,031r	100.0			9,031r	7,778r	100.0		7,778r
- roads		9,089r	100.0			9,089r	7,653r	100.0		7,653r
c) Salvage cutting - special plans ⁵		8,949r	100.0			8,949r	4,718r	100.0		4,718r
d) Other methods		7,690r	99.1	66r	0.9	7,756r	6,380r	99.8	10r	0.2
Subtotal		42,604r	99.8	66r	0.2	42,670r	34,844r	100.0	10r	0.0
10) Treatments carried out under the resource development program		1,375r	100.0			1,375r	546r	100.0		546r
Total		337,296r	99.9	275r	0.1	337,571r	300,356r	99.9	183r	0.1
Grand total		577,035r	98.5	8,852r	1.5	585,887r	534,012r	98.8	6,511r	1.2

1. Updated January 3, 2008.

2. TSFMA : Timber supply and forest management agreement holders.

3. MRNF : Ministère des Ressources naturelles et de la Faune.

4. SBBA : stacking, branching and bucking area.

5. Areas disturbed by natural disasters, etc.

5 Forest management

Summary of silvicultural treatments carried out (cont'd)

05.14.02

A) Public forests (cont'd)

Type of treatments	Area (2004-2005) ¹					Area (2005-2006) ¹				
	TSFMA ²		MRNF ³		Total	TSFMA ²		MRNF ³		Total
	(ha)	(%)	(ha)	(%)	(ha)	(ha)	(%)	(ha)	(%)	(ha)
Site preparation ⁴										
1) Scarifying	43,682r	100r			43,682r	48,690r	100.0			48,690r
2) Clearing	5,059r	100.0			5,059r	4,784r	100.0			4,784r
3) Brushing	135r	17.1	654r	82.9	789r					
4) Controlled slash burning										
5) Controlled burning						776r				776r
6) Removal of residual stems	338r	82.6	71r	17.4	409r	1,665r	100.0			1,665r
Total	49,214r	98.5	725r	1.5	49,939r	55,915r	100.0			55,915r
Reforestation and seeding										
1) Planting	(ha)									
	(Seedlings, million)									
2) Reinforcement	(ha)									
	(Seedlings, million)									
3) Enrichment	(ha)									
	(Seedlings, million)									
4) Regeneration of SBBA ⁵	Natural (ha)									
	Artificial (ha)									
	(Seedlings, million)									
5) Seeding	(ha)									
Total	(ha)									
	(Seedlings, million)									
Noncommercial treatments										
1) Release (plantations)	11,852r	99.9	16r	0.1	11,868r	5,550r	100.0			5,550r
2) Release (natural regeneration)	4,253r	100.0			4,253r	796r	100.0			796r
3) Pre-commercial thinning	98,280r	98.1	1,917r	1.9	100,197r	63,522r	99.1	557r	0.9	64,078r
4) Phytosanitary control	2r	0.7	291r	99.3	293r			60r	100.0	60r
5) Fertilization	211r	100.0			211r	94r	100.0			94r
6) Drainage	3,864r	100.0			3,864r	3,936r	100.0			3,936r
Total	118,462r	98.2	2,224r	1.8	120,686r	73,898r	99.2	617r	0.8	74,514r
Commercial treatments										
1) a) Cutting with protection of regeneration and soils	97,030r	100.0			97,030r	96,157r	99.8	200r	0.2	96,357r
b) Merchantable trees	1,809r	100.0			1,809r	1,281r	100.0			1,281r
c) Tall regeneration	531r	100.0			531r	876r	100.0			876r
d) With seed reserve	1,227r	100.0			1,227r	570r	100.0			570r
Subtotal (CPRS)	100,597r	100.0			100,597r	98,883r	99.8	200r	0.2	99,083r
2) Block cutting	126,729r	100.0			126,729r	101,848r	100.0			101,848r
3) a) Selection cutting	27,847r	100.0			27,847r	13,598r	100.0			13,598r
b) Pre-selection cutting	3,542r	100.0			3,542r	1,391r	100.0			1,391r
Subtotal	31,389r	100.0			31,389r	14,988r	100.0			14,988r
4) Improvement cutting	46r	100.0			46r	258r	100.0			258r
5) Shelterwood cutting	3,132r	100.0			3,132r	1,754r	100.0			1,754r
6) Commercial thinning	7,810r	97.5	201r	2.5	8,011r	6,889r	100.0			6,889r
7) a) Strip cutting	814r	100.0			814r	246r	100.0			246r
b) Patch cutting										
Subtotal	814r	100.0			814r	246r	100.0			246r
8) Harvesting in buffer strips	1,458r	100.0			1,458r	2,257r	100.0			2,257r
9) Other methods :										
a) Cutting for reforestation	6,915r	100.0			6,915r	1,719r	100.0			1,719r
b) Clear cutting - SBBA	8,309r	100.0			8,309r	4,029r	100.0			4,029r
- Roads	7,627r	100.0			7,627r	4,346r	100.0			4,346r
c) Salvage cutting - special plans ⁶	3,855r	100.0			3,855r	7,974r	100.0			7,974r
d) Other methods	10,616r	99.7	29r	0.3	10,645r	16,606r	100.0			16,606r
Subtotal	37,322r	99.9	29r	0.1	37,351r	34,674r	100.0			34,674r
10) Treatments carried out under the resource development program										
Total	309,297r	99.9	230r	0.1	309,527r	261,798r	99.9	200r	0.1	261,998r
Grand total	543,474r	99.4	3,179r	0.6	546,653r	459,591r	99.8	817r	0.2	460,407r

1. Updated January 3, 2008.

2. TSFMA : Timber supply and forest management agreement holders.

3. MRNF : Ministère des Ressources naturelles et de la Faune.

4. Updated February 3, 2010.

5. SBBA : stacking, branching and bucking area.

6. Areas disturbed by natural disasters, etc.

N.B. : The treatments was approx. 160,000 ha short in 2005-2006.

5 Forest management

Summary of silvicultural treatments carried out (cont'd)

A) Public forests (cont'd)

05.14.03

Type of treatments	Area (2006-2007) ¹					Area (2007-2008) ¹					
	TSFMA ²		MRNF ³		Total	TSFMA ²		MRNF ³		Total	
	(ha)	(%)	(ha)	(%)	(ha)	(ha)	(%)	(ha)	(%)	(ha)	
Site preparation											
1) Scarifying	55,719r	100.0			55,719r	57,733r	100.0			57,733r	
2) Clearing	7,013r	100.0			7,013r	7,468r	100.0			7,468r	
3) Brushing											
4) Harrowing	3,048r	100.0			3,048r	4,253r	100.0			4,253r	
5) Controlled burning											
6) Removal of residual stems	2,045r	100.0			2,045r	1,293r	100.0			1,293r	
Total	67,825r	100.0			67,825r	70,747r	100.0			70,747r	
Reforestation and seeding											
1) Planting	(ha) 48,708r	100.0			48,708r	50,669r	100.0			50,669r	
	(Seedlings, million) 81r	100.0			81r	93r	100.0			93r	
2) Reinforcement	(ha) 23,532r	100.0			23,532r	14,279r	100.0			14,279r	
	(Seedlings, million) 22r	100.0			22r	12r	100.0			12r	
3) Enrichment	(ha) 502r	100.0			502r	264r	100.0			264r	
	(Seedlings, million)									0r	
4) Regeneration of SBBA ⁴	Natural (ha)									0r	
	Artificial (ha) 6,787r	100.0			6,787r	4,320r	100.0			4,320r	
	(Seedlings, million) 11r	100.0			11r	7r	100.0			7r	
5) Seeding	(ha) 634r	100.0			634r	589r	100.0			589r	
Total	(ha) 80,163r	100.0			80,163r	70,121r	100.0			70,121r	
	(Seedlings, million) 114r	100.0			114r	112r	100.0			112r	
Noncommercial treatments											
1) Release (plantations)	11,902r	100.0			11,902r	10,317r	100.0			10,317r	
2) Release (natural regeneration)	1,861r	100.0			1,861r	2,673r	100.0			2,673r	
3) Pre-commercial thinning	83,041r	100.0			83,041r	69,045r	100.0			69,045r	
4) Phytosanitary control	104r	100.0			104r	265r	100.0			265r	
5) Fertilization	2r	100.0			2r	80r	100.0			80r	
6) Drainage	2,743r	100.0			2,743r	2,277r	100.0			2,277r	
Total	99,653r	100.0			99,653r	84,657r	100.0			84,657r	
Commercial treatments											
1) a) Cutting with protection of regeneration and soils	169,612r	100.0			169,612r	143,405r	100.0			143,405r	
b) Merchantable trees	3,389r	100.0			3,389r	1,860r	100.0			1,860r	
c) Tall regeneration	7,572r	100.0			7,572r	1,062r	100.0			1,062r	
d) With seed reserve	1,586r	100.0			1,586r	1,640r	100.0			1,640r	
Subtotal (CPRS)	182,159r	100.0			182,159r	147,967r	100.0			147,967r	
2) Block cutting	96,056r	100.0			96,056r	61,247r	100.0			61,247r	
3) a) Selection cutting	8,692r	100.0			8,692r	8,143r	100.0			8,143r	
b) Pre-selection cutting	1,123r	100.0			1,123r	1,504r	100.0			1,504r	
Subtotal	9,815r	100.0			9,815r	9,647r	100.0			9,647r	
4) Improvement cutting	17r	100.0			17r						
5) Shelterwood cutting	2,434r	100.0			2,434r	3,075r	100.0			3,075r	
6) Commercial thinning	4,700r	100.0			4,700r	6,016r	100.0			6,016r	
7) a) Strip cutting	395r	100.0			395r	149r	100.0			149r	
b) Patch cutting											
Subtotal	7,546r	100.0			7,546r	9,240r	100.0			9,240r	
8) Harvesting in buffer strips	833r	100.0			833r	424r	100.0			424r	
9) Other methods :											
a) Cutting for reforestation											
b) Clear cutting - SBBA											
- Roads											
c) Salvage cutting - special plans ⁵	13,065r	100.0			13,065r	54,121r	100.0			54,121r	
d) Other methods	7,783r	100.0			7,783r	3,971r	100.0			3,971r	
Subtotal	8,616r	100.0			8,616r	4,395r	100.0			4,395r	
10) Treatments carried out under the resource development program	1,282r	100.0			1,282r	503r				503r	
Total	208,136r	100.0			208,136r	171,249r	100.0			171,249r	
Grand total	455,777r	100.0			455,777r	396,774r	100.0			396,774r	

1. Annual report of intervention forest area conducted by the beneficiaries from 2006-2007 and 2007-2008 up to July 2009.

2. TSFMA : Timber supply and forest management agreement holders.

3. MRNF : Ministère des Ressources naturelles et de la Faune.

4. SBBA : stacking, branching and bucking area.

5. Areas disturbed by natural disasters, etc.

N.B. : The CPRS and the other cuts has been estimated in 2006 and 2007. The treatments was approx. 15,000 ha short in 2006-2007.

The treatments was approx. 85,000 ha short in 2007-2008.

5 Forest management

Summary of silvicultural treatments carried out (cont'd)

A) Public forests (cont'd)

05.14.04

Type of treatments	Area (2008-2009) ¹				Total (ha)
	TSFMA ²		MRNF ³		
	(ha)	(%)	(ha)	(%)	
Site preparation					
1) Scarifying	63,168p	100.0			63,168p
2) Clearing	4,970p	100.0			4,970p
3) Brushing					
4) Harrowing	5,636p	100.0			5,636p
5) Controlled burning					
6) Removal of residual stems					
Total	73,774p	100.0			73,774p
Reforestation and seeding					
1) Planting	(ha) 60,027p	100.0			60,027p
	(Seedlings, million) 133p	100.0			133p
2) Reinforcement	(ha) 5,695p	100.0			5,695p
	(Seedlings, million) 11p	100.0			11p
3) Enrichment	(ha) 54p	100.0			54p
	(Seedlings, million)				
4) Regeneration of SBBA ⁴	Natural (ha)				
	Artificial (ha)				
	(Seedlings, million)				
5) Seeding	(ha)				
Total	(ha) 65,776p	100.0			65,776p
	(Seedlings, million) 144p	100.0			144p
Noncommercial treatments					
1) Release (plantations)	9,493p	100.0			9,493p
2) Release (natural regeneration)	3,693p	100.0			3,693p
3) Pre-commercial thinning	58,670p	100.0			58,670p
4) Phytosanitary control	4p	100.0			4p
5) Fertilization					
6) Drainage	2,049p	100.0			2,049p
Total	73,909p	100.0			73,909p
Commercial treatments					
1) a) Cutting with protection of regeneration and soils	116,665p	100.0			116,665p
b) Merchantable trees	1p	100.0			1p
c) Tall regeneration	1p	100.0			1p
d) With seed reserve	1p	100.0			1p
Subtotal (CPRS)	116,668p	100.0			116,668p
2) Block cutting	1p	100.0			1p
3) a) Selection cutting	9,730p	100.0			9,730p
b) Pre-selection cutting	1,238p	100.0			1,238p
Subtotal	10,968p	100.0			10,968p
4) Improvement cutting	1p				1p
5) Shelterwood cutting	3,054p	100.0			3,054p
6) Commercial thinning	3,064p	100.0			3,064p
7) a) Strip cutting	435p	100.0			435p
b) Patch cutting	1p	100.0			1p
Subtotal	6,555p	100.0			6,555p
8) Harvesting in buffer strips	1p	100.0			1p
9) Other methods :					
a) Cutting for reforestation	1p	100.0			1p
b) Clear cutting - SBBA	1p	100.0			1p
- Roads	1p	100.0			1p
c) Salvage cutting - special plans ⁵	1p	100.0			1p
d) Other methods	6,492p	100.0			6,492p
Subtotal	6,496p	100.0			6,496p
10) Treatments carried out under the resource development program	1p				1p
Total	140,687p	100.0			140,687p
Grand total	354,146p	100.0			354,146p

1. According to the state of silvicultural treatments from 2008-2009 up to august 20, 2009.

2. TSFMA : Timber supply and forest management agreement holders.

3. MRNF : Ministère des Ressources naturelles et de la Faune.

4. SBBA : stacking, branching and bucking area.

5. Areas disturbed by natural disasters, etc.

N.B. : The CPRS and the other cuts has been estimated in 2006 and 2007. The treatments was approx. 15,000 ha short in 2006-2007.

The treatments was approx. 85,000 ha short in 2007-2008.

5 Forest management

Summary of silvicultural treatments carried out (cont'd)

05.14.05

B) Private forests ¹

Type of treatments	Area (2004-2005) ²	Area (2005-2006) ²	Area (2006-2007) ²	Area (2007-2008) ²	Area (2008-2009) ²
	(ha)	(ha)	(ha)	(ha)	(ha)
Site preparation					
1) Scarifying	609	542p	312p	508p	314p
2) Clearing	3,188	3,663p	3,416p	3,104p	2,969p
3) Ploughing and harrowing	164	193p	199p	286p	354p
4) Brushing					
- mechanical	2,955	2,680p	2,543p	2,579p	2,251p
- chemical				2p	
5) Removal of residual stems	592	450p	456p	430p	356p
6) Other treatments	665	656p	642p	696p	672p
Total	8,173	8,185p	7,568p	7,605p	6,916p
Reforestation					
1) Planting	8,672	7,967p	7,961p	7,338p	7,135p
2) Reinforcement	1,193	1,109p	1,139p	1,054p	1,031p
3) Enrichment	216	159p	197p	182p	118p
Total	10,082	9,235p	9,298p	8,574p	8,284p
(Seedlings, million)	22	20r	20r	19r	18r
Noncommercial treatments					
1) Release (plantations)					
- mechanical	11,413	11,114p	11,743p	11,272p	11,385p
- chemical				40p	18p
2) Release (natural regeneration)					
- mechanical	325	256p	349p	410p	385p
- chemical					
3) Pre-commercial thinning	6,013	5,745p	5,539p	5,920p	6,295p
4) Phytosanitary control	467	568p	777p	618p	680p
5) Drainage	825	514p	442p	403p	323p
Total	19,043	18,197p	18,850p	18,663p	19,087p
Commercial treatments					
1) Selection cutting	1,745	1,933p	2,114p	2,289p	2,020p
2) Shelterwood cutting	531	620p	1,307p	562p	351p
3) Strip and patch cutting	22	9p	24p	27p	6p
4) Commercial thinning	4,636	5,620p	6,283p	5,858p	4,257p
5) Other methods	4,932	5,236p	4,599p	5,794p	5,572p
Total	11,866	13,418p	14,327p	14,530p	12,206p
Grand total	49,164	49,034p	50,043p	49,372p	46,493p

1. All types of treatments are also carried out annually by woodlot owners with personal or business entitlement, beyond the scope of these subsidy programs. These treatments are not included in the present data.

2. The data include all of the programs that have been managed by agencies for private forest development (Example : PMVFP, specific expectations, employment creation programs, section 2, faunal projects, etc.)

Source : The private forest data are drawn from the regular program (PFDSP) to which the rexforêt program is added for the fiscal years 2002-2003, 2003-2004, and 2004-2004

6 Use of forests for educational, leisure, research and experimental purposes

Highlights

Teaching and research forests (TRF), July 2009

06.00.01

Teaching and research forests (no.)	16
Area (ha, 000s)	38.7

N.B. : The Duchesnay Forest Station is now under the responsibility of SÉPAQ.

Experimental forests (EF), August 2009

Permanent (no.)	197
Temporary (no.)	436
Total (no.)	633
Area (ha, 000s)	24

Principal wildlife-related activities ¹

	Participants (no.)	Expenditures (\$M)	Jobs (no.)	Added value (\$M)
Fishing ²	813,600	1,047.8	9,754	457.9
Hunting ²	408,000	308.4	3,322	157.3
Outdoor activities	2,350,600	1,269.5	15,656	700.7
Wildlife-related travel ²	1,211,800	303.4	3,379	162.6

1. Updated 2000.

2. Non-residents' expenditures, jobs and added value are not included because they are not available.

7 Non-timber use

Non-timber forest products (NTFPs)

Highlights

Volume and value of large-container maple production, farm sales and home consumption

07.00.01

		2006r	2007p	2008p
Bulk syrup	(kg, 000s)	27,859	23,541	22,226
	(\$, 000s)	132,050	114,180	156,800
Direct sales by producers	(kg, 000s)	4,164	4,073	4,073
	(\$, 000s)	27,540	26,940	27,390
Producers' consumption	(kg, 000s)	372	372	372
	(\$, 000s)	2,460	2,460	2,500
Bulk syrup (stock)	(kg, 000s)	264	-	-
	(\$, 000s)	1,250	-	-
Marketed and self-sufficient production	(kg, 000s)	32,659	27,986	26,671
	(\$, 000s)	163,300	143,580	186,690
Total production	(kg, 000s)	32,659	27,986	26,671
	(\$, 000s)	163,300	143,580	186,690

Sources : Ministère de l'Agriculture, des Pêcheries et de l'Alimentation (November 23, 2008).
Institut de la statistique du Québec

Sale of wild blueberries from blueberry farms and forests in Québec

Year		Fresh fruit sales			Sales to processors			Total sales
		Farms	Forests	Total	Farms	Forests	Total	
2006	Quantity (t)	864.1	408.2	1,272.3	24,040.4	6,803.9	30,844.3	32,116.6
	Value (\$, 000s)	705.7	1,260.0	1,965.7	50,350.0	15,450.0	65,800.0	67,765.7
2007	Quantity (t)	487.6	272.2	759.8	13,982.0	4,789.9	18,771.9	19,531.7
	Value (\$, 000s)	2,687.5	1,500.0	4,187.5	29,283.8	12,144.0	41,427.8	45,615.3
2008	Quantité (t)	1,595.0	22,115.3	6,226.7	28,342.0	29,937.0
	Valeur ('000 \$)	6,180.0	26,693.8	12,526.2	39,220.0	45,400.0

Sources : Ministère de l'Agriculture, des Pêcheries et de l'Alimentation du Québec.
Institut de la statistique du Québec

Bulk Christmas tree production

	2006		2007		2008	
	Number	Value (\$)	Number	Value (\$)	Nombre	Valeur (\$)
Québec	20 000 000e	49 261 000e	13 100 000e	32 255 000e	13 100 000e	29 000 000e

Source : Background National Forestry Database Program, Compendium of Canadian Forestry Statistics, forest product sector.

Québec's essential oil industry

Year	Number of plants ¹	Imports ² (\$, 000s)	Exports ² (\$, 000s)	Re-Exports ^{2,3} (\$, 000s)
2006	12	306	0.4	0
2007	10	456	78.7	2.1
2008	11	734	12.7	0

1. Directory of essential oil producers in Québec (Essential oils: 3771.010).

2. Statistics Canada – SH330130 – Essential oils.

3. "Re-Export" means export of merchandise produced from imported raw materials.

8 Logging

Highlights

Economic indicators for the Québec forestry and logging industry (NAICS 113)

08.00.01

	2006	2007
Total jobs (no.)	12,823	12,037
Total salaries and wages (\$, 000s)	531,371	474,734
Total revenue (\$, 000s)	3,089,201	3,020,490
Capital expenditures and repairs (\$, 000s)	143,900	142,100

Sources : Statistics Canada : 61-205, 61-206 and CANSIM.

9 Timber use

Highlights

09.00.01

Consumption of Québec's primary wood

Processing plants in 2008 (m³, 000s)

By species	
• FSPL	39 916
• Other softwoods	1 498
• Poplars	3 491
• Hardwoods	6 908
• Total	51 813
By type of timber use	
• Roundwood	30 442
• Chips	14 908
• Sawdust, shavings, wood residues and bark	6 463
• Total	51 813
By source	
• Public forests	21 273
• Private forests	4 732
• Exchange between mills	18 512
• Outside Québec	7 295
• Total	51 813
By product	
• Pulp and paper	19 831
• Saw timber	24 118
• Peelers	273
• Panelboard	3 732
• Other	3 859
• Total	51 813

Balance of Québec's bark in 2008 (BDMT, 000s)

Estimated production	2 421
Use	2 996
Projects ¹	(575)

1. Steam boiler, pyrolysis, electricity generation and cogeneration projects.

Trade with markets outside Québec in 2008 (m³, 000s)

Region or country	Receipts	Shipments
Ontario		
• Softwoods	969,5	94,2
• Hardwoods	877,5	0,0
Other provinces		
• Softwoods	645,6	509,8
• Hardwoods	374,3	9,7
United States and other countries		
• Softwoods	2 922,4	750,4
• Hardwoods	1 506,0	47,4
Total		
• Softwoods	4 537,6	1 354,4
• Hardwoods	2 757,8	57,0

Principal products of Québec's primary wood processing plants

	2008
Pulp destined for sale (BDMT)	1 476 696
Paper (BDMT)	5 744 430
Paperboard (BDMT)	1 359 401
Insulation board (mt)	7 385
Particle board (m ³)	2 528 944
Veneer (m ²)	52 744 220
Shingles (squares)	553 351
Poles (units)	18 525
Mulching material (BDMT)	29 122
Charcoal (mt)	4 937
Saw timber (bd ft, 000s)	4 977 064
Other products (bd ft, 000s) ¹	95 797

1. Other products: fuel pellets, electricity, turning and shaping, laths, etc.

FSPL chip stocks at Québec's sawmills

	December 1999	Décember 2008
FSPL chips (BDMT, 000s)	81,1	54,9

9 Timber use

Trade with markets outside Québec

09.05.01

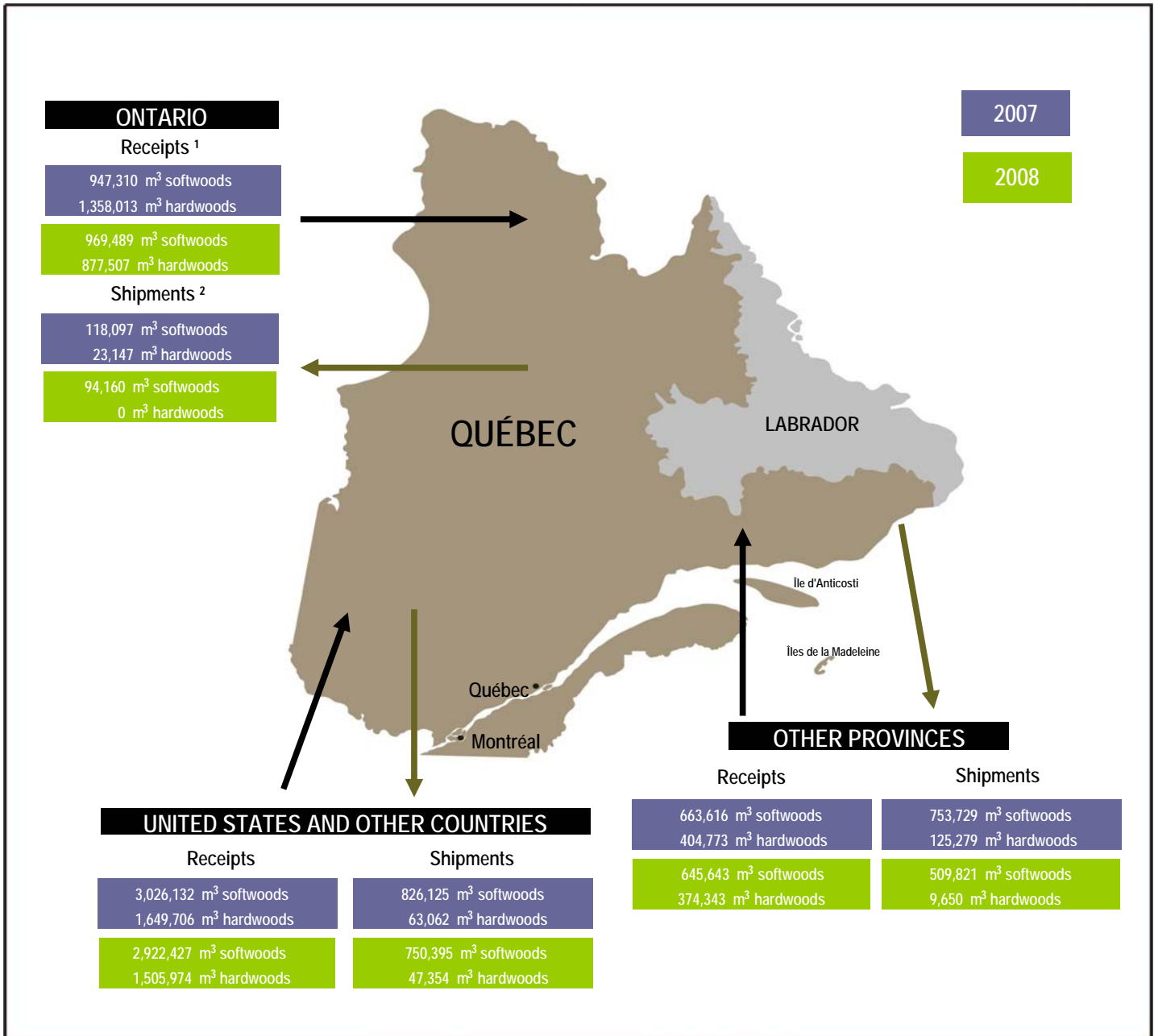

1. Receipts of roundwood, chips, sawdust and bark from outside Québec.

2. Shipments of chips, sawdust and bark outside Québec, estimated destination breakdown.

Source : Forestry Register, Division de l'évaluation de la demande, DDIPF, ministère des Ressources naturelles et de la Faune.

10 Wood industries

Highlights

10.00.01

Québec's primary wood processing plants in 2008

Lumber	321
Pulp and paper ¹	30
Veneer and plywood	12
Particle board	9
Wood turning and shaping	5
Energy production and cogeneration ²	22
Other	5
Total	404

1. The remaining 27 pulp, paper and paperboard mills do not consume round-wood, chips, sawdust or shavings.

2. Mills producing electricity, pellets and fuel chips.

Source : Forestry Register, Ministère des Ressources naturelles et de la Faune.

Establishments by wood processing groups and sub-groups in 2007

Wood product manufacturing	1,577
Paper manufacturing	308
Total	1,885

Source : Statistics Canada (According to the annual report on logging and manufacturing).

Economic indicators for Québec's wood products industry (NAICS 321) in 2007

Jobs (no.)	31,740
Salaries and wages (\$, 000s)	1,276,843
Value of shipments and other revenue (\$, 000s)	7,946,008
Value added ¹ to total activity (\$, 000s)	3,685,933
Capital expenditures and repairs (\$, 000s)	699,300

1. The value added to total activity has been estimated.

Sources : Statistics Canada (According to the annual report on logging and manufacturing).
Institut de la statistique du Québec, Investissements privés et publics au Québec

Québec's lumber production (m³, 000s)

2004	• Résineux	19,414
	• Feuillus	1,112
2005	• Résineux	17,599
	• Feuillus	1,008
2006	• Résineux	16,302
	• Feuillus	934
2007	• Résineux	13,798
	• Feuillus	791
2008	• Résineux	11,729
	• Feuillus	672

Source: Statistics Canada: 35-003.

Source of wood used by Québec's sawmills in 2008 (m³, 000s)

Public forests	17,816.1
Private forests	2,480.8
Other mills	26.9
Outside Québec	3,794.4
Total	24,118.1

Source : Forestry Register, Ministère des Ressources naturelles et de la Faune.

Joint production of Québec's sawmills in 2008 (BDMT, 000s)

Chips	5,282
Sawdust and shavings	1,309
Bark	1,772
Total	8,363

Source : Forestry Register, Ministère des Ressources naturelles et de la Faune.

Québec's lumber shipments in 2008 (m³, 000s)

Softwoods	9,827.8
Hardwoods	1,021.7
Total	10,849.5

Source : Forestry Register, Ministère des Ressources naturelles et de la Faune.

Destination of Québec's lumber shipments (%)

	2007		2008	
	Softwoods	Hardwoods	Softwoods	Hardwoods
Canada	63.1	67.9	67.9	72.5
United States	35.8	18.8	31.4	16.6
Overseas	1.1	13.3	0.7	10.9
Total	100.0	100.0	100.0	100.0

Sources : Statistics Canada and Ministère des Ressources naturelles et de la Faune du Québec (Forestry register).

10 Wood industries

Highlights (cont'd)

Economic indicators for Québec's sawmills and wood preservation industries (NAICS 32111) in 2007

Jobs (no.)	12,543
Salaries and wages (\$, 000s)	523,680
Value of shipments and other revenue (\$, 000s)	374,670
Value added ¹ to total activity (\$, 000s)	980,038
Capital expenditures and repairs (\$, 000s)	..

1. The value added to the total activity has been estimated.

Economic indicators of Québec's sawmills, excluding shingle mills (NAICS 32111) in 2007

Jobs (no.)	11,562
Salaries and wages (\$, 000s)	489,752
Value of shipments and other revenue (\$, 000s)	3,254,999
Value added ¹ to total activity (\$, 000s)	884,031
Capital expenditures and repairs (\$, 000s)	..

1. The value added to the total activity has been estimated.

Sources : Statistics Canada (According to the annual report on logging and manufacturing).
Institut de la statistique du Québec, Investissements privés et publics au Québec

Volume and value of Québec's lumber exports by destination in 2008

	Volume (m ³ , 000s)	Value (\$, millions)
United States and Mexico	4,536.4	645.5
Europe	70.7	61.8
Middle East and Africa	189.6	57.6
Asia and Oceania	44.8	37.7
Central and South America	9.2	4.0
Total	4,850.8	806.7

Source : Institut de la statistique du Québec.

Economic indicators for Québec's veneer, plywood and reconstituted wood industry (NAICS 3212) in 2007

Jobs (no.)	5,459
Salaries and wages (\$, 000s)	225,952
Value of shipments and other revenue (\$, 000s)	1,609,687
Value added ¹ to total activity (\$, 000s)	637,926
Capital expenditures and repairs (\$, 000s)	..

1. The value added to the total activity has been estimated.

Source : Statistics Canada (According to the annual report on logging and manufacturing).

Economic indicators for Québec's particle board industry

	2008	2009
Jobs (no.)	1,922	1,684
Mills (no.)	12	11
Production capacity (m ³ , 000s/year)	4,592	4,142
Capital expenditures and repairs (\$, 000s)

Sources : Ministère des Ressources naturelles et de la Faune, Direction du développement de l'industrie des produits forestières (internal compilation).

Economic indicators for Québec's waferboard industry (NAICS 321217) ¹ in 2006

Jobs (no.)	652
Salaries and wages (\$, 000s)	36,993
Value of shipments and other revenue (\$, 000s)	379,903
Value added ² to total activity (\$, 000s)	145,515

1. NAICS 321217 corresponds to the oriented strand board (OSB) industry.

2. The value added to the total activity has been estimated.

Source : Statistics Canada (According to the annual report on logging and manufacturing).

Québec's balance of trade ¹ in the wood products sector ² (\$, million)

Wood, charcoal and wood products	Exports	Imports	Balance of trade
2006	3,640.5	981.8	2,658.6
2007	2,848.0	888.5	1,959.6
2008	2,080.9	806.9	1,274.1

1. Balance of trade of commercial goods with international destinations.

2. Product descriptors consistent with the Harmonized Commodity Description and Coding System (World Customs Organization).

Source : Institut de la statistique du Québec, according to the Standard Classification of Goods

Québec's balance of trade ¹ in the wood products sector ² (\$, million)

Wood product manufacturing (NAICS 321)	Exports	Imports	Balance of trade
2006	3,548.6	648.9	2,899.7
2007	2,780.8	618.0	2,162.8
2008	2,031.7	582.6	1,449.1

1. Balance of trade of commercial goods with international destinations.

2. According to NAICS.

Source : Institut de la statistique du Québec.

10 Wood industries

Highlights

10.00.01 (2)

Québec's primary wood processing plants in 2008

Lumber	321
Pulp and paper ¹	30
Veneer and plywood	12
Particle board	9
Wood turning and shaping	5
Energy production and cogeneration ²	22
Other	5
Total	404

1. The remaining 27 pulp, paper and paperboard mills do not consume round-wood, chips, sawdust or shavings.

2. Mills producing electricity, pellets and fuel chips.

Source : Forestry Register, Ministère des Ressources naturelles et de la Faune.

Establishments by wood processing groups and sub-groups

(including furniture and printing) in 2007

Wood product manufacturing	1,577
Furniture and related product manufacturing	2,800
Paper manufacturing	308
Printing and related support activities	1,834
Total	6,519

Source : Statistics Canada (According to the annual report on logging and manufacturing).

Economic indicators for Québec's wood products industry (NAICS 321) in 2007

Jobs (no.)	31,740
Salaries and wages (\$, 000s)	1,276,843
Value of shipments and other revenue (\$, 000s)	7,946,008
Value added ¹ to total activity (\$, 000s)	3,685,933
Capital expenditures and repairs (\$, 000s)	699,300

1. The value added to the total activity has been estimated.

Sources : Statistics Canada (According to the annual report on logging and manufacturing).
Institut de la statistique du Québec, Investissements privés et publics au Québec

Economic indicators for Québec's furniture and related product manufacturing industry (NAICS 337) in 2007

Jobs (no.)	30,712
Salaries and wages (\$, 000s)	998,422
Value of shipments and other revenue (\$, 000s)	3,906,318
Value added ¹ to total activity (\$, 000s)	2,133,587
Capital expenditures and repairs (\$, 000s)	134,000

1. The value added to the total activity has been estimated.

Source : Statistics Canada (According to the annual report on logging and manufacturing).

Québec's lumber production (m³, 000s)

2004	• Résineux	19,414
	• Feuillus	1,112
2005	• Résineux	17,599
	• Feuillus	1,008
2006	• Résineux	16,302
	• Feuillus	934
2007	• Résineux	13,798
	• Feuillus	791
2008	• Résineux	11,729
	• Feuillus	672

Source : Statistics Canada : 35-003.

Québec's furniture and related product production industry (NAICS 337) (\$, 000s)

2004	4,261,634
2005	4,119,378
2006	3,936,123
2007	3,906,318

Source : Institut de la statistique du Québec (principal statistics on the total activity)

Source of wood used by Québec's sawmills in 2008 (m³, 000s)

Public forests	17,816.1
Private forests	2,480.8
Other mills	26.9
Outside Québec	3,794.4
Total	24,118.1

Source : Forestry Register, Ministère des Ressources naturelles et de la Faune.

Joint production of Québec's sawmills in 2008 (BDMT, 000s)

Chips	5,282
Sawdust and shavings	1,309
Bark	1,772
Total	8,363

Source : Forestry Register, Ministère des Ressources naturelles et de la Faune.

Québec's lumber shipments in 2008 (m³, 000s)

Softwoods	9,827.8
Hardwoods	1,021.7
Total	10,849.5

Source : Forestry Register, Ministère des Ressources naturelles et de la Faune.

10 Wood industries Highlights (cont'd)

10.00.01 (2)

Destination of Québec's lumber shipments in 2008 (%)

	Softwoods	Hardwoods
Canada	67.9	72.5
United States	31.4	16.6
Overseas	0.7	10.9
Total	100.0	100.0

Source : Statistics Canada and Ministère des Ressources naturelles et de la Faune du Québec (Forestry register).

Economic indicators for Québec's sawmills and wood preservation industries (NAICS 32111) in 2007

Jobs (no.)	12,543
Salaries and wages (\$, 000s)	523,680
Value of shipments and other revenue (\$, 000s)	374,670
Value added ¹ to total activity (\$, 000s)	980,038
Capital expenditures and repairs (\$, 000s)	..

1. The value added to the total activity has been estimated.

Sources : Statistics Canada (According to the annual report on logging and manufacturing).
Institut de la statistique du Québec, Investissements privés et publics au Québec

Economic indicators of Québec's sawmills, excluding shingle mills (NAICS 32111) in 2007

Jobs (no.)	11,562
Salaries and wages (\$, 000s)	489,752
Value of shipments and other revenue (\$, 000s)	3,254,999
Value added ¹ to total activity (\$, 000s)	884,031
Capital expenditures and repairs (\$, 000s)	..

1. The value added to the total activity has been estimated.

Source : Statistics Canada (According to the annual report on logging and manufacturing).

Volume and value of Québec's lumber exports by destination in 2008

	Volume (m ³ , 000s)	Value (\$, millions)
United States and Mexico	4,536.4	645.5
Europe	70.7	61.8
Middle East and Africa	189.6	57.6
Asia and Oceania	44.8	37.7
Central and South America	9.2	4.0
Total	4,850.8	806.7

Source : Institut de la statistique du Québec.

Economic indicators for Québec's veneer, plywood and reconstituted wood industry (NAICS 3212) ¹ in 2007

Jobs (no.)	5,459
Salaries and wages (\$, 000s)	225,952
Value of shipments and other revenue (\$, 000s)	1,609,687
Value added ¹ to total activity (\$, 000s)	637,926
Capital expenditures and repair (\$, 000s)	..

1. The value added to the total activity has been estimated.

Source : Statistics Canada (According to the annual report on logging and manufacturing).

Economic indicators for Québec's particle board industry

	2008	2009
Jobs (no.)	1,922	1,684
Mills (no.)	12	11
Production capacity (m ³ , 000s/year)	4,592	4,142
Capital expenditures and repairs (\$, 000s)

Source : Ministère des Ressources naturelles et de la Faune, Direction du développement de l'industrie des produits forestières (internal compilation)

Economic indicators for Québec's waferboard industry (NAICS 321217) ¹ in 2006

Jobs (no.)	652
Salaries and wages (\$, 000s)	36,993
Value of shipments and other revenue (\$, 000s)	379,903
Value added ² to total activity (\$, 000s)	145,515

1. NAICS 321217 corresponds to the oriented strand board (OSB) industry.

2. The value added to the total activity has been estimated.

Source : Statistics Canada (According to the annual report on logging and manufacturing).

Québec's balance of trade ¹ in the furniture ² manufacturing sector (\$, million)

Furniture and related product manufacturing	Exports	Imports	Balance of trade
2006	1,369.0	730.8	638.2
2007	1,057.2	773.6	283.6
2008	832.0	842.2	-10.2

1. Balance of trade of commercial goods with international destinations.

2. According to NAICS.

Source : Institut de la statistique du Québec.

Québec's balance of trade ¹ in the wood and furniture ² manufacturing sector (\$, million)

Wood product and furniture and related product manufacturing	Exports	Imports	Balance of trade
2006	4,917.6	1,379.7	3,537.9
2007	3,838.0	1,391.6	2,446.4
2008	2,863.7	1,424.8	1,438.9

1. Balance of trade of commercial goods with international destinations.

2. According to NAICS.

Source : Institut de la statistique du Québec.

10 Wood industries

Overview

Timber production in Québec (softwoods and hardwoods)

(m³, 000s)

10.01.09

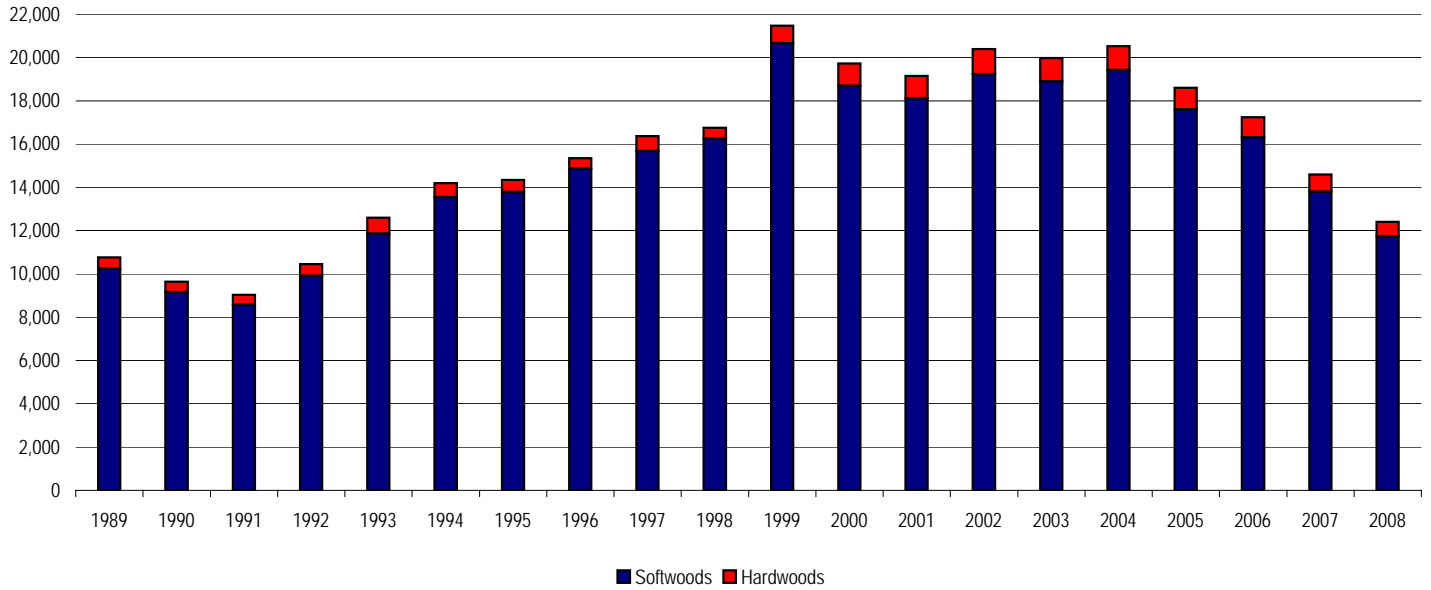

Sources: Statistics Canada: 35-002 (1987 to 1995) and 35-003.

10 Wood industries

The sawmill industry

Sawmills by size ¹ in 2008

10.02.01

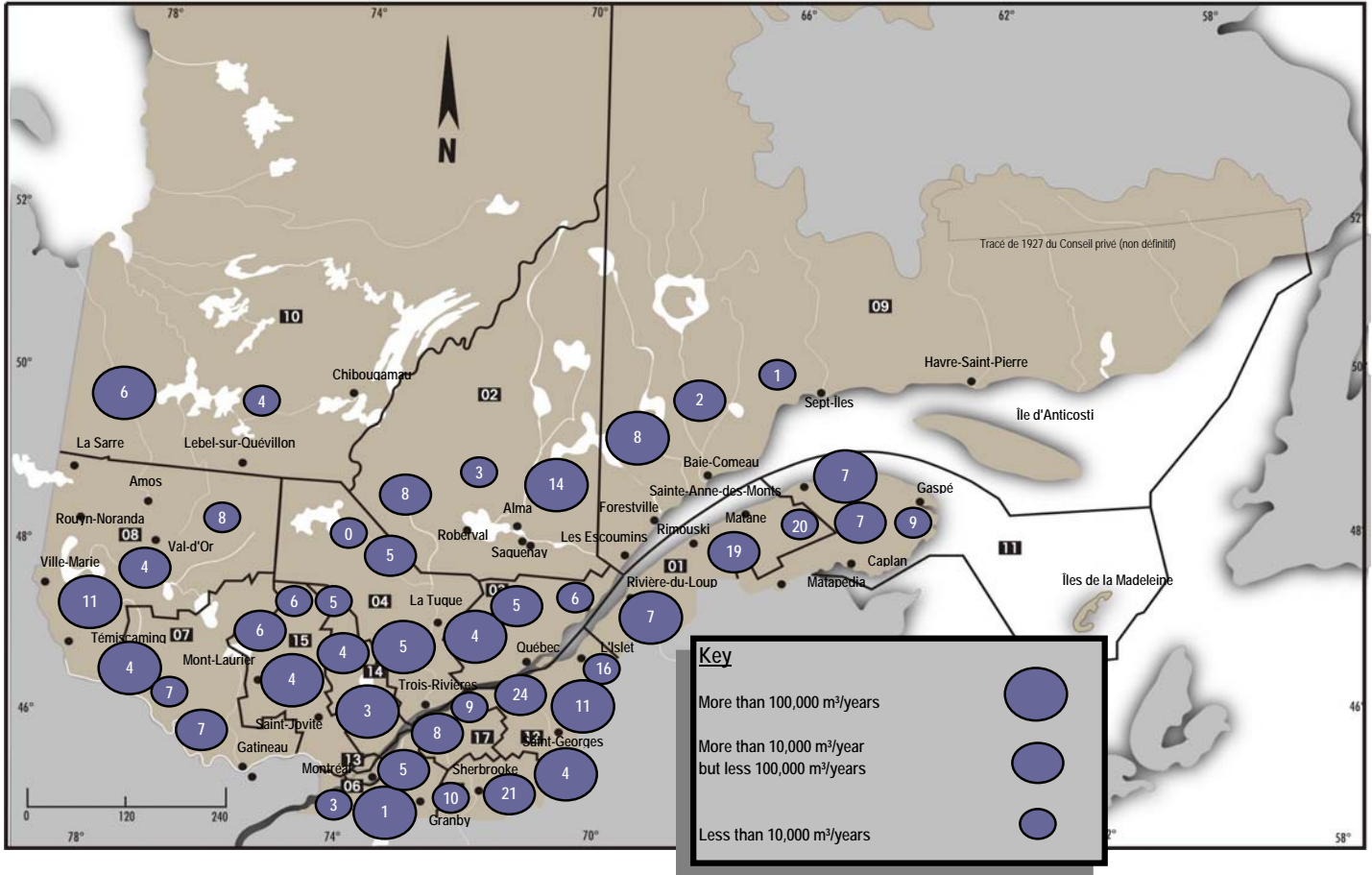

1. Mill size on authorized wood consumption volumes.

Source : Ministère des ressources naturelles et de la Faune, Direction du développement de l'industrie des produits forestiers (Forestry register).

10 Wood industries

The sawmill industry (cont'd)

Timber sawmill output (fir, spruce, jack pine, larch) (TSFMA¹ holders) in 2007

(m³/1 000 bd ft)

10.02.06

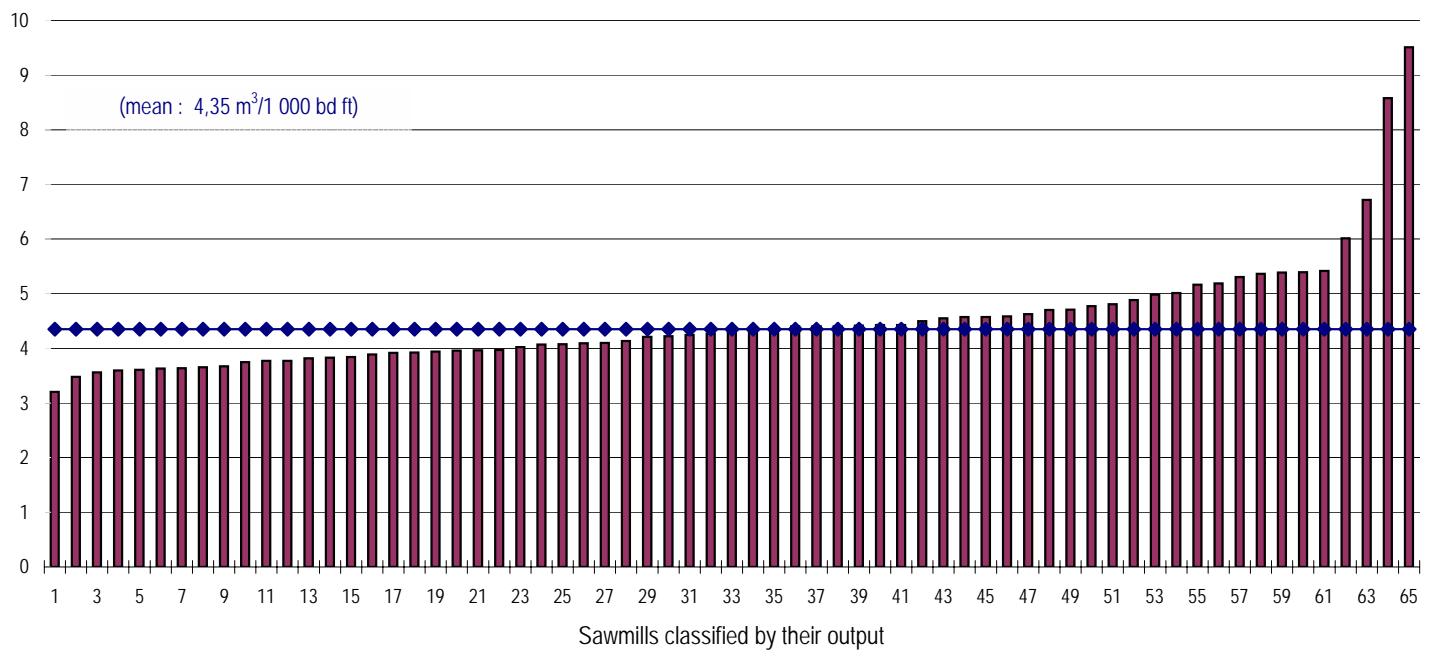

Timber sawmill output (fir, spruce, jack pine, larch) (TSFMA¹ holders) in 2008

(m³/1 000 bd ft)

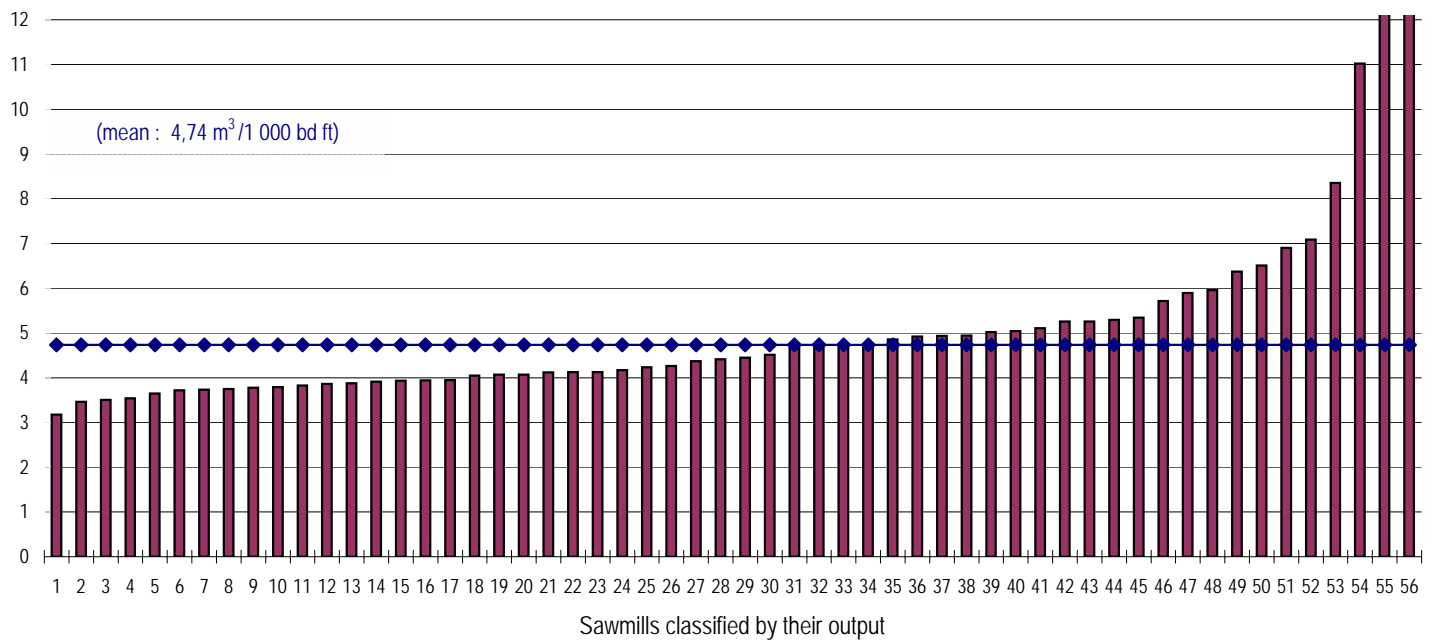

1. TSFMA : timber supply and forest management agreement.

11 The pulp and paper industry

Highlights

11.00.01

Québec's pulp, paper and paperboard mills in June 2008

Mills consuming roundwood, chips, sawdust and shavings (primary processing mills)	30
Mills consuming market pulp and recycled fibres	27
Total	57

Source : Forestry Register, Ministère des Ressources naturelles et de la Faune.

Québec's pulp, paper and paperboard mills and production capacity in June 2009¹

	Mills (no.)	Production capacity (BDMT, 000s/year)
Market pulp	8	3,465.1
Newsprint (mechanical, supercalandered, etc.)	18	4,888.8
Paperboard packaging and others	10	1,426.1
Low-density board	2	110.0
Fine and specialty paper	3	895.8
Construction paperboard	1	18.0
Kraft papers (packing, carbon)	2	103.2
Sanitary tissue	13	668.8
Total	57	11,575.7

1. Classification by main product.

Source : Forestry Register, Ministère des Ressources naturelles et de la Faune.

Establishments by paper manufacturing industry sub-groups (NAICS 322)

	2007
Mechanical pulp mills	5
Chemical pulp mills	11
Paper (except newsprint) mills	35
Newsprint mills	18
Paperboard mills	25
Corrugated and solid paperboard box manufacturing	39
Folding paperboard box manufacturing	27
Other paperboard container manufacturing	24
Paper bag and coated and treated paper manufacturing	51
Stationery product manufacturing	31
Sanitary paper product manufacturing	15
All other converted paper product manufacturing	27
Total	308

Source : Statistics Canada (According to the annual report on logging and manufacturing).

Main timber supply sources for Québec's pulp and paper industry in 2008 (m³, 000s)

Roundwood and chips (public forests)	2,026.6
Roundwood and chips (private forests)	1,875.2
Roundwood, chips, sawdust and shavings from Québec's mills	13,245.2
Roundwood, chips, sawdust and shavings from outside Québec	2,378.1
Total	19,525.0

Source : Forestry Register, Ministère des Ressources naturelles et de la Faune.

Raw materials used in Québec's pulp and paper mills in 2008 (BDMT, 000s)

Roundwood	1,961.0
Joint sawmill production	6,334.0
Recycled fibres and commercial pulp	2,643.0
Total	10,938.0

Source : Forestry Register, Ministère des Ressources naturelles et de la Faune.

Recycled fibre from paper and paperboard recycled by Québec's pulp and paper industry in 2008 (BDMT, 000s)

Recovered paper for de-inking	1,097.8
Recovered paper, without de-inking	180.2
Recovered paperboard for de-inking	659.9
Total	1,937.9

Source : Forestry Register, Ministère des Ressources naturelles et de la Faune.

Types of pulp produced by Québec's pulp and paper industry (mt, 000s)

	2007	2008
Sulphate pulp (Kraft)	1,813	1,725
Thermomechanical pulp	4,147	3,658
Recycled pulp	1,792	1,196
Other pulp	378	308
Total	8,130	6,886

Source : Forestry Register, Ministère des Ressources naturelles et de la Faune.

Québec's paper and paperboard production (mt, 000s)

	2007	2008
Newsprint	3,270	3,036
Printing and writing papers	2,878	2,558
Sanitary tissue	371	334
Other papers	151	266
Paperboard	1,618	1,446
Total	8,289	7,640

Source : Forestry Register, Ministère des Ressources naturelles et de la Faune.

Québec's share of Canadian paper and paperboard production (mt, 000s)

	2007		2008	
	Newsprint	Other paper and paperboard	Newsprint	Other paper and paperboard
Québec	3,071	5,104	3,001	4,511
Canada	6,640	10,431	6,400	9,765
Québec/Canada (%)	46.3	48.9	46.9	46.2

Sources : Conseil des industries forestières du Québec (CIFQ).
Conseil des produits des pâtes et papiers (CPPP).

Economic indicators for Québec's paper products industry (NAICS 322) in 2007

Jobs (no.)	23,571
Salaries and wages (\$, 000s)	1,389,101
Value of shipments and other revenue (\$, 000s)	10,138,535
Value added ¹ to total activity (\$, 000s)	3,796,211
Capital expenditures and repair (\$, 000s)	690,800

1. The value added to the total activity has been estimated.

Source : Statistics Canada (According to the annual report on logging and manufacturing).

11 Pulp and paper industry Highlights (cont'd)

11.00.01

Economic indicators for Québec's wood pulp, paper and paperboard industry (NAICS 3221) in 2007

Jobs (no.)	14,084
Salaries and wages (\$, 000s)	901,067
Value of shipments and other revenue (\$, 000s)	7,205,487
Value added ¹ to total activity (\$, 000s)	2,535,851
Capital expenditures and repairs (\$, 000s)	..

1. The value added to the total activity has been estimated.

Source : Statistics Canada (According to the annual report on logging and manufacturing).

Destination of Québec's pulp and paper shipments in 2007 (mt, 000s)

	Canada	United States	Other countries	Total
Newsprint	463	1,745	823	3,031
Market pulp	196	263	695	1,154
Other paper and paperboard	1,719	3,116	246	5,081
Total	2,378	5,124	1,764	9,266

Source : Conseil des industries forestières du Québec (CIFQ).

Destination of Québec's pulp and paper shipments in 2008 (tm, 000s)

	Canada	United States	Other countries	Total
Newsprint	428	1,463	1,119	3,010
Market pulp	145	274	637	1,056
Other paper and paperboard	1,639	2,583	269	4,491
Total	2,212	4,320	2,025	8,557

Source : Conseil des industries forestières du Québec (CIFQ).

Relative share of Québec's pulp and paper exports (\$, million)

	2006	2007	2008
Pulp and paper exports	7,932.1	7,228.7	7,268.8
Total exports	73,195.8	69,924.1	71,022.1
Relative share (%)	10.8	10.3	10.2

Sources : Statistics Canada : 65-003 and Institut de la statistique du Québec.

Share of Québec's newsprint exports on US market (mt, 000s)

	2006	2007	2008
Québec's shipments to the US	2,050	1,745	1,463
US newsprint consumption	8,673	7,716	6,990p
Relative share (%)	23.6	22.6	20.9p

Source : Institut de la statistique du Québec and Conseil des produits des pâtes et papiers (CPPP).

Québec's balance of trade¹ in the pulp and paper sector² in 2008 (\$, million)

	Exports	Imports	Balance of trade
Woodpulp or pulp derived from other cellulosic fibrous materials, paper or paperboard for recycling (waste and residues)	1,051.1	216.6	834.5
Paper or paperboard; cellulose products, in paper or paperboard	6,101.1	1,094.6	5,006.5
Total	7,152.2	1,311.2	5,841.0

1. Balance of trade of commercial goods with international destinations.

2. Product descriptors consistent with the Harmonized Commodity Description and Coding System (World Customs Organization).

Source : Institut de la statistique du Québec.

Québec's balance of trade¹ in the pulp and paper² products manufacturing sector in 2008 (\$, million)

	Exports	Imports	Balance of trade
Pulp, paper and paperboard mills (NAICS 3221)	6,355.1	817.7	5,537.4
Converted paper product manufacturing (NAICS 3222)	694.7	325.5	369.2
Total	7,049.8	1,143.2	5,906.6

1. Balance of trade of commercial goods with international destinations.

2. According to NAICS.

Source : Institut de la statistique du Québec.

Environmental protection

	1981	2007	2007 / 1981
Total suspended solids (TSS) in mill effluent (kg/ton of pulp produced)	26.0	1.7	-94 %
Biochemical oxygen demand (BOD ₅) in mill effluent (kg/ton of pulp produced)	59.1	0.9	-98 %
Water consumption by mills (m ³ /ton of pulp produced)	121.0	48.9	-60 %

Source : Ministère du Développement durable, de l'Environnement et des Parcs.

11 The pulp and paper industry

Highlights

11.00.01 (2)

Québec's pulp, paper and paperboard mills in June 2009

Mills consuming roundwood, chips, sawdust and shavings (primary processing mills)	30
Mills consuming market pulp and recycled fibres	27
Total	57

Source : Forestry Register, Ministère des Ressources naturelles et de la Faune.

Québec's pulp, paper and paperboard mills and production capacity in June 2009¹

	Mills (no.)	Production capacity (BDMT, 000s/year)
Market pulp	8	3,465.1
Newsprint (mechanical, supercalandered, etc.)	18	4,888.8
Paperboard packaging and others	10	1,426.1
Low-density board	2	110.0
Fine and specialty paper	3	895.8
Construction paperboard	1	18.0
Kraft papers (packing, carbon)	2	103.2
Sanitary tissue	13	668.8
Total	57	11,575.7

1. Classification by main product.

Source : Forestry Register, Ministère des Ressources naturelles et de la Faune.

Establishments by paper manufacturing industry sub-groups (NAICS 322)

	2007
Mechanical pulp mills	5
Chemical pulp mills	11
Paper (except newsprint) mills	35
Newsprint mills	18
Paperboard mills	25
Corrugated and solid paperboard box manufacturing	39
Folding paperboard box manufacturing	27
Other paperboard container manufacturing	24
Paper bag and coated and treated paper manufacturing	51
Stationery product manufacturing	31
Sanitary paper product manufacturing	15
All other converted paper product manufacturing	27
Total	308

Source : Statistics Canada (According to the annual report on logging and manufacturing)

Establishments by printing and related support activities industry sub-groups (NAICS 323)

	2007
Commercial screen printing	173
Quick printing	82
Digital printing	92
Manifold business forms printing	114
Other printing	1,082
Support activities for printing	291
Total	1,834

Source : Statistics Canada (According to the annual report on logging and manufacturing)

Main timber supply sources for Québec's pulp and paper industry in 2008 (m³, 000s)

Roundwood and chips (public forests)	2,026.6
Roundwood and chips (private forests)	1,875.2
Roundwood, chips, sawdust and shavings from Québec's mills	13,245.2
Roundwood, chips, sawdust and shavings from outside Québec	2,378.1
Total	19,525.0

Source : Forestry Register, Ministère des Ressources naturelles et de la Faune.

Raw materials used in Québec's pulp and paper mills in 2008 (BDMT, 000s)

Roundwood	1,961.0
Joint sawmill production	6,334.0
Recycled fibres and commercial pulp	2,643.0
Total	10,938.0

Source : Forestry Register, Ministère des Ressources naturelles et de la Faune.

Recycled fibre from paper and paperboard recycled by Québec's pulp and paper industry in 2008 (BDMT, 000s)

Recovered paper for de-inking	1,097.8
Recovered paper, without de-inking	180.2
Recovered paperboard, without de-inking	659.9
Total	1,937.9

Source : Forestry Register, Ministère des Ressources naturelles et de la Faune.

Types of pulp produced by Québec's pulp and paper industry (mt, 000s)

	2007	2008
Sulphate pulp (Kraft)	1,813	1,725
Thermomechanical pulp	4,147	3,658
Recycled pulp	1,792	1,196
Other pulp	378	308
Total	8,130	6,886

Source : Forestry Register, Ministère des Ressources naturelles et de la Faune.

Québec's paper and paperboard production (mt, 000s)

	2007	2008
Newsprint	3,270	3,036
Printing and writing papers	2,878	2,558
Sanitary tissue	371	334
Other papers	151	266
Paperboard	1,618	1,446
Total	8,289	7,640

Source : Forestry Register, Ministère des Ressources naturelles et de la Faune.

Québec's share of Canadian paper and paperboard production (mt, 000s)

	2007		2008	
	Newsprint	Other paper and paperboard	Newsprint	Other paper and paperboard
Québec	3,071	5,104	3,036	4,604
Canada	6,640	10,431	6,400	9,765
Québec/Canada (%)	46.3	48.9	47.4	47.1

Sources : Conseil des industries forestières du Québec (CIFQ).
Conseil des produits des pâtes et papiers (CPPP).

11 Pulp and paper industry Highlights (cont'd)

11.00.01 (2)

Québec's printing and related support activities production industry (NAICS 323) (\$, 000s)

2004	3,473,584
2005	3,315,565
2006	3,225,022
2007	3,332,805

Source : Institut de la statistique du Québec (principal statistics on total activity).

Economic indicators for Québec's paper products industry (NAICS 322) in 2007

Jobs (no.)	23,571
Salaries and wages (\$, 000s)	1,389,101
Value of shipments and other revenue (\$, 000s)	10,138,535
Value added ¹ to total activity (\$, 000s)	3,796,211
Capital expenditures and repair (\$, 000s)	690,800

1. The value added to total activity has been estimated.

Source : Statistics Canada (According to the annual report on logging and manufacturing).

Economic indicators for Québec's wood pulp, paper and paperboard industry (NAICS 3221) in 2007

Jobs (no.)	14,084
Salaries and wages (\$, 000s)	901,067
Value of shipments and other revenue (\$, 000s)	7,205,487
Value added ¹ to total activity (\$, 000s)	2,535,851
Capital expenditures and repairs (\$, 000s)	...

1. The value added to total activity has been estimated.

Source : Statistics Canada (According to the annual report on logging and manufacturing).

Destination of Québec's pulp and paper shipments in 2007 (mt, 000s)

	Canada	United States	Other countries	Total
Newsprint	463	1,745	823	3,031
Market pulp	196	263	695	1,154
Other paper and paperboard	1,719	3,116	246	5,081
Total	2,378	5,124	1,764	9,266

Source : Conseil des industries forestières du Québec (CIFQ).

Destination of Québec's pulp and paper shipments in 2008 (tm, 000s)

	Canada	United States	Other countries	Total
Newsprint	428	1,463	1,119	3,010
Market pulp	145	274	637	1,056
Other paper and paperboard	1,639	2,583	269	4,491
Total	2,212	4,320	2,025	8,557

Source : Conseil des industries forestières du Québec (CIFQ).

Relative share of Québec's pulp and paper exports (\$, million)

	2006	2007	2008
Pulp and paper exports	7,932.1	7,228.7	7,268.8
Total exports	73,195.8	69,924.1	71,022.1
Relative share (%)	10.8	10.3	10.2

Sources : Statistics Canada : 65-003 and Institut de la statistique du Québec.

Share of Québec's newsprint exports on US market (mt, 000s)

	2006	2007	2008
Québec's shipments to the US	2,050	1,745	1,463
US newsprint consumption	8,673	7,716	6,990p
Relative share (%)	23.6	22.6	20.9p

Sources : Institut de la statistique du Québec and Conseil des produits des pâtes et papiers (CPPPP).

Economic indicators for Québec's printing and related support activities (NAICS 323) in 2007

Jobs (no.)	18,885
Salaries and wages (\$, 000s)	835,106
Value of shipments and other revenue (\$, 000s)	3,332,805
Value added ¹ to total activity (\$, 000s)	1,915,812
Capital expenditures and repair (\$, 000s)	186,000

1. The value added to total activity has been estimated.

Source : Statistics Canada (According to the annual report on logging and manufacturing).

Québec's balance of trade¹ in the printing and related activities² sector in 2008 (\$, million)

	Exports	Imports	Balance of trade
Printing and related support activities	375.2	173.4	201.8

1. Balance of trade of commercial goods with international destinations.

2. According to NAICS.

Source : Institut de la statistique du Québec.

Québec's balance of trade¹ in the pulp and paper, printing and related support activities manufacturing² in 2008 (\$, million)

	Exports	Imports	Balance of trade
Pulp and paper manufacturing	7,049.8	1,142.9	5,906.9
Printing and related support activities	375.2	173.7	201.5
Total	7,425.0	1,316.6	6,108.4

1. Balance of trade of commercial goods with international destinations.

2. According to NAICS.

Source : Institut de la statistique du Québec.

Environmental protection

	1981	2007	2007 / 1981
Total suspended solids (TSS) in mill effluent (kg/ton of pulp produced)	26.0	1.7	-94 %
Biochemical oxygen demand (BOD ₅) in mill effluent (kg/ton of pulp produced)	59.1	0.9	-98 %
Water consumption by mills (m ³ /ton of pulp produced)	121.0	48.9	-60 %

Source : Ministère du Développement durable, de l'Environnement et des Parcs.

11 The pulp and paper industry

Production capacity

Pulp, paper and paperboard mills, June 2008¹

11.01.01

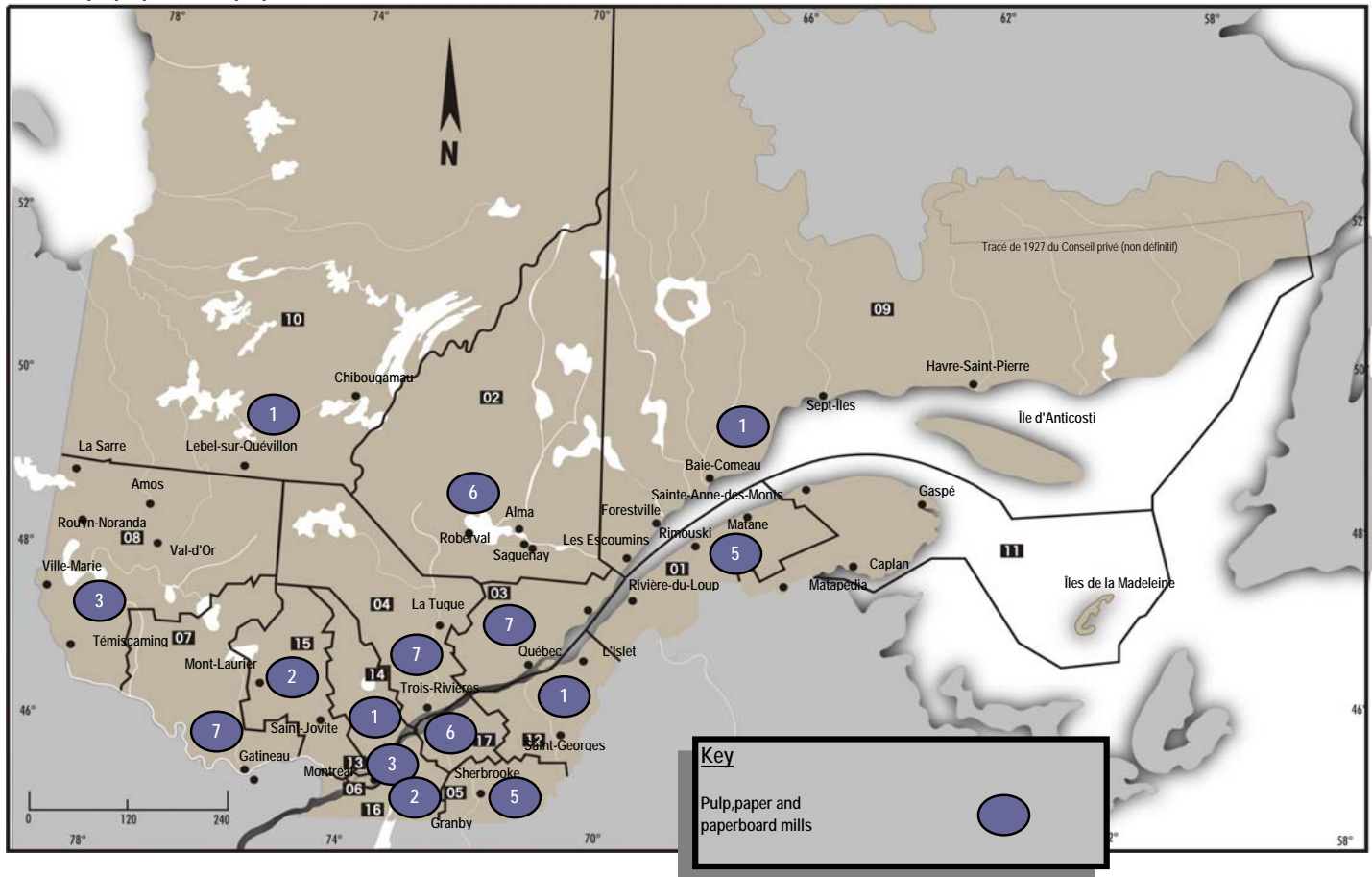

1. There are no pulp and paper mills in the regions of Gaspésie-Îles-de-la-Madeleine (11) and Laval (13).

Source : Ministère des Ressources naturelles et de la Faune, Direction du développement de l'industrie des produits forestiers (Forestry Register).

11 The pulp and paper industry

Production

Breakdown of production by product

11.02.05

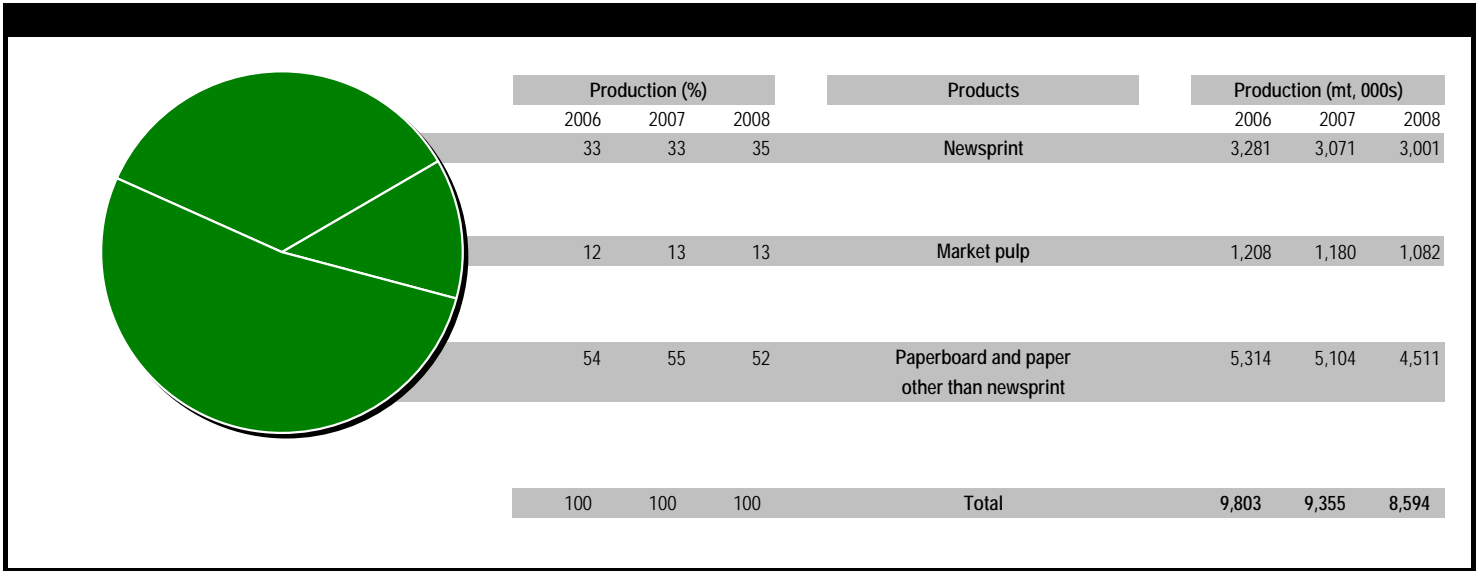

Source : Québec's Forest Industry Council (QFIC).

11 The pulp and paper industry

Environment

Trends in the quality of effluents from Québec's pulp and paper mills

(kg/ton of pulp produced)

11.06.02

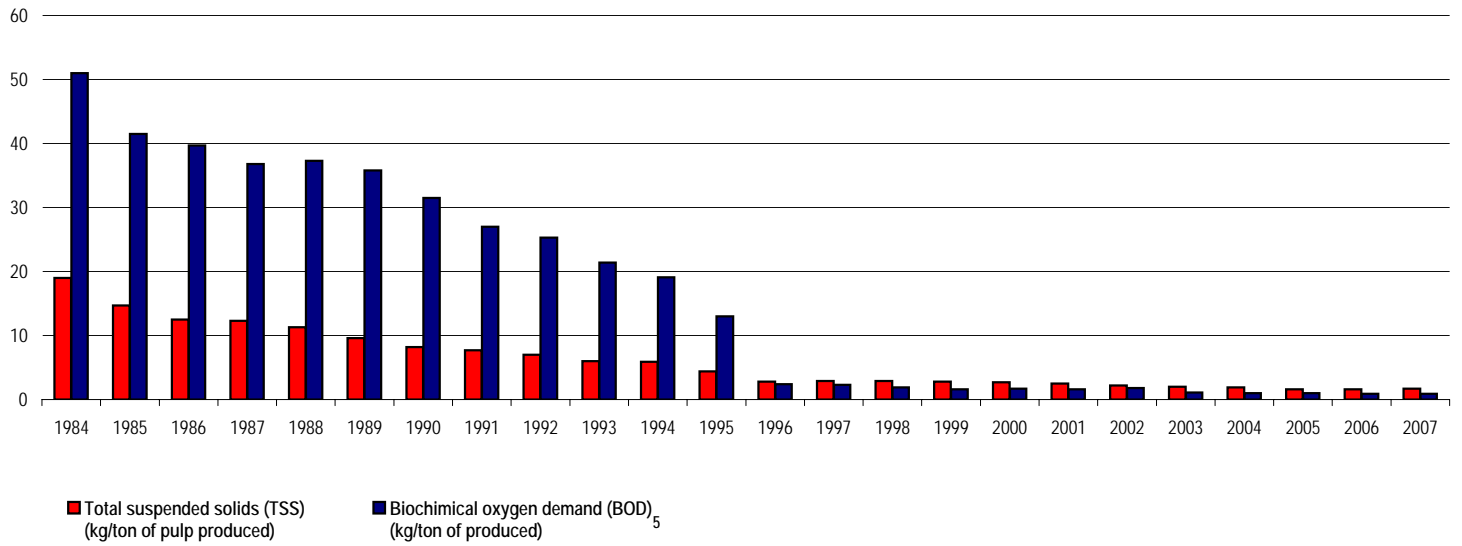

Source : Ministère du Développement durable, de l'Environnement et des Parcs.

11 The pulp and paper industry

Environment (cont'd)

Where did Québec's paper mill waste go in 2007?

11.06.05

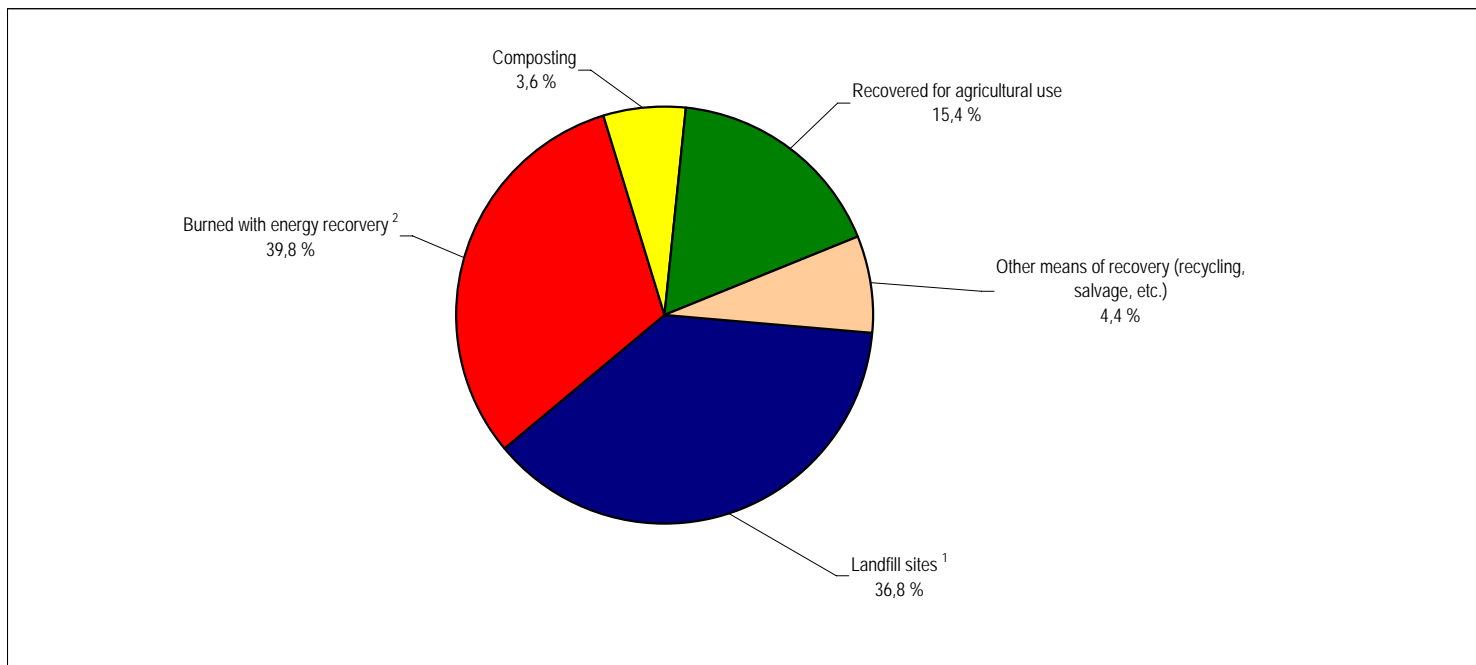

1. Including sites set aside for production waste or solid waste landfill sites.

Source : Ministère du Développement durable, de l'Environnement et des Parcs.

12 The forest sector in Québec's economy

Highlights

Economic indicators for Québec's forest products industry in 2007

12.00.01

	Total jobs (no.)	Total salaries and wages (\$, 000s)	Value of shipments and other revenue (\$, 000s)	Value added ¹ to total activity (\$, 000s)
Forestry and logging (NAICS 113)	12,037	474,734	3,020,490	1,093,621
Wood product manufacturing (NAICS 321)	31,740	1,276,843	7,946,008	2,952,631
Paper manufacturing (NAICS 322)	23,571	1,389,101	10,138,535	3,796,211
Total (forest sector)	67,348	3,140,678	21,105,033	7,842,463
Overall manufacturing activity in Québec	451,724	20,736,263	156,321,340	66,779,941

1. The value added to total activity has been estimated according to the following calculation : (Manufactured goods revenue + Total closing stocks – Total opening stocks – Energy and water supply costs – Supplies and material costs).

Sources : Statistics Canada (According to the annual report on logging and manufacturing of 2004) and Institut de la statistique du Québec.

Economic importance of Québec's forest product exports¹ (\$, million)

	2007	2008
Raw wood, sawn wood and lumber	2,847.8	2,080.9
Pulp, paper and paperboard	7,287.5	7,699.2
Total (forest sector)	10,135.4	9,780.1

1. Based on customs data, according to the Standard Classification of Goods (SCG).

Gross domestic product (GDP)¹ at factor cost by economic activity² in 2008

	(\$, million)	(% change)
Forestry and logging (NAICS 113)	836.4	-14.1
Wood product manufacturing (NAICS 321)	2,564.7	-13.8
Paper manufacturing (NAICS 3221 and 3222)	3,423.1	-9.5
Economy as a whole	248,270.3	1.2

1. GDP by sector of activity measures the added value of each industrial sector, i.e. production value less intermediate consumption value.

2. In chained (2002) dollars.

Source : Statistics Canada.

Value of Québec's shipments, principal forest products (\$, million)

	2008	2009
Sawmills	2,758	1,909
Other prefabricated millwork	864	813
Oriented strand board (OSB)	91	78
Particle board	584	547
Wooden doors and windows	731	655
Wooden boxes and pallets	196	168
Wooden structural products	329	
Wooden kitchen cabinets	810	731
Wood pulp	990	629
Newsprint	3,105	2,305
Paperboard	886	778
Paperboard containers	1,169	1,174

Source : Institut de la statistique du Québec.

Construction starts in Canada and the United States (no. of units)

	2008	2009
Canada	211,056	138,356
United States	905,500	547,000

Source : Société canadienne d'hypothèques et de logement and US Census Bureau.

Québec's balance of trade¹ in the forest products sector and for all products² in 2008 (\$, million)

	Imports	Exports	Balance of trade
Wood, wood charcoal and wood products			
Pulp, paper and paperboard	806.8	2,080.9	1,274.1
	1,311.2	7,152.2	5,841.0
Total (forest products sector)	2,118.0	9,233.1	7,115.1
All products	87,573.0	71,022.1	-16,550.9

1. Balance of trade of commercial goods with international destinations.

2. Product descriptors consistent with the Harmonized Commodity Description and Coding System (World Customs Organization).

Source : Institut de la statistique du Québec, according to the Standard Classification of Goods.

Québec's balance of trade¹ in the forest products sector and for all products² in 2008 (\$, million)

	Imports	Exports	Balance of trade
Wood product manufacturing	582.6	2,031.7	1,449.1
Wood pulp, paper and paperboard, converted paper product manufacturing mills	1,143.2	7,049.8	5,906.6
Total (forest products sector)	1,725.8	9,081.5	7,355.7
All products	87,573.0	71,022.1	-16,550.9

1. Balance of trade of commercial goods with international destinations.

2. According to (NAICS).

Source : Institut de la statistique du Québec.

Financial indicators

	2008	2009
Average exchange rate (C\$/US\$)	1.066	1.142
Average exchange rate (C\$/€)	1.962	1.780
Average exchange rate (C\$/¥)	1.560	1.586
Average exchange rate (C\$/¥)	0.010	0.012
Average discount rate		
• Canada (%)	3.21	0.65
• United States (%)	1.84	0.16
Average prime rate		
• Canada (%)	4.73	2.40
• United States (%)	4.88	3.25
Stock market index (paper and forest product market prices, Toronto Exchange)	8,987.70	11,746.11

Source : Bank of Canada and <http://www.djindexes.com>.

12 The forest sector in Québec's economy

Highlights (cont'd)

12.00.01

Average price of principal forest products

	2008	2009
Softwood lumber, Toronto green (composite price) (C\$/1,000 bd ft)	248.3	230.2
Softwood lumber, Columbus dry (composite price) (C\$/1,000 bd ft)	300.3	289.7
Hardwood lumber, Montreal exchange (weighted price) (C\$/1,000 bd ft)	563.6	508.2
Plywood (12.5 mm) (C\$/1,000 sq.ft.)	433.0	..
Oriented strand board (OSB) 7/16" (C\$/1,000 sq.ft.)	190.0	206.0
Bleached softwood kraft pulp (US\$/mt)	740.0	830.0
Bleached hardwood kraft pulp (US\$/mt)	665.0	715.0
Newsprint (US\$/mt)	530.0	580.0

Sources : Pribec, Madison's Canadian Lumber Reporter, Random Lengths Publications, RISI, Inc.

Estimated revenue from wood chips in Québec (C\$/1 000 bd ft) ¹

	2008	2009
	129.0	125.0

1. Estimated revenue for every 1,000 bd ft produced.

Source : Ministère des Ressources naturelles et de la Faune (internal compilation).

Profits made by Canada's forest products industry

	2007	2008
Profits (\$, million)	247	-6
Profits/sales (%)	1.2	-0.1

Source : Statistics Canada : 61-008.

Share of paper mill-integrated sawmills in authorized roundwood consumption

1987	28.1 % of total consumption
2008	46.8 % of total consumption

Source : Ministère des Ressources naturelles et de la Faune (internal compilation).

Budget allocated to the secteur des forêts and the secteur des services régionaux, MRNF ¹, 2008-2009 ² (\$, 000s)

Research and development	9,921.0
Forestry policies and programs	166,579.8
Forest management planning and monitoring	64,200.0
Seedling production	39,842.1
Internal management and support	900.0
Forestry loans	500.0
Total	281,942.9

1. Ministère des Ressources naturelles et de la Faune.

2. Including Forestry Fund (financed jointly by the MRNF and the industry) :
forestry research, forest surveys, seedling production, planning and control.

Source : Ministère des Ressources naturelles et de la Faune, Direction des ressources financières (internal compilation).

12 The forest sector in Québec's economy

Highlights

12.00.01 (2)

Economic indicators for Québec's forest products industry in 2007 (including furniture and printing)

	Total jobs (no.)	Total salaries and wages (\$, 000s)	Value of shipments and other revenue (\$, 000s)	Value added ¹ to total activity (\$, 000s)
Forestry and logging (NAICS 113)	12,037	474,734	3,020,490	1,093,621
Wood product manufacturing (NAICS 321)	31,740	1,276,843	7,946,008	2,952,631
Furniture and related product manufacturing (NAICS 337)	30,712	998,422	3,906,318	2,133,587
Paper manufacturing (NAICS 322)	23,571	1,389,101	10,138,535	3,796,211
Printing and related support activities (NAICS 323)	18,885	835,106	3,332,805	1,915,812
Total (forest sector)	116,945	4,974,206	28,344,156	11,891,862
Overall manufacturing activity in Québec	451,724	20,736,263	156,321,340	66,779,941

1. The value added to total activity has been estimated according to the following calculation : (Manufactured goods revenue + Total closing stocks – Total opening stocks – Energy and water supply costs – Supplies and material costs).

Sources : Statistics Canada (According to the annual report on logging and manufacturing of 2004) and Institut de la statistique du Québec

Economic importance of Québec's forest product exports (including furniture and printing)¹ (\$, million)

	2007	2008
Forestry and logging (NAICS 113)	12.1	6.3
Wood product manufacturing (NAICS 321)	2,780.8	2,031.6
Furniture and related product manufacturing (NAICS 337)	1,057.0	831.9
Paper manufacturing (NAICS 3221 and 3222)	6,617.2	7,049.7
Printing and related support activities (NAICS 323)	429.8	375.1
Total (forest sector)	10,896.9	10,294.7

1. According to NAICS.

Source : Statistics Canada (Stratégis).

Gross domestic product (GDP)¹ at factor cost by economic activity in 2008² (including furniture and printing)

	(\$, million)	(% change)
Forestry and logging (NAICS 113)	836.4	-14.1
Wood product manufacturing (NAICS 321)	2,564.7	-13.8
Furniture and related product manufacturing (NAICS 337)	1,656.4	-6.9
Paper manufacturing (NAICS 3221 and 3222)	3,423.1	-9.5
Printing and related support activities (NAICS 323)	1,487.1	5.5
Economy as a whole	248,270.3	1.2

1. GDP by sector of activity measures the added value of each industrial sector, i.e. production value less intermediate consumption value.

2. In chained (2002) dollars.

Source : Statistics Canada.

Value of Québec's shipments, principal forest products (including furniture and printing) (\$, million)

	2008	2009
Sawmills	2,758	1,909
Other prefabricated millwork	864	813
Oriented strand board (OSB)	91	78
Particle board	584	547
Wooden doors and windows	731	655
Wooden boxes and pallets	196	168
Wooden structural products	329	
Wooden kitchen cabinets	810	731
Furniture	3,702	3,215
Wood pulp	990	629
Newsprint	3,105	2,305
Paperboard	886	778
Cardboard containers	1,169	1,174
Printing	2,709	2,633

Source : Institut de la statistique du Québec.

Construction starts in Canada and the United States (no. of units)

	2008	2009
Canada	211,056	138,356
United States	905,500	547,000

Sources : Société canadienne d'hypothèques et de logement and US Census Bureau.

Québec's balance of trade¹ in the forest products sector and for all products² in 2008 (including furniture and printing) (\$, million)

	Imports	Exports	Balance of trade
Wood product, furniture and related product manufacturing	1,424.8	2,863.7	1,438.9
Wood pulp, paper and paperboard, converted paper product manufacturing and printing and related support activities mills	1,226.8	7,046.9	6,108.1
Total (forest products sector)	2,651.6	9,910.6	7,547.0
All products	87,573.0	71,022.1	-16,550.9

1. Balance of trade of commercial goods with international destinations.

2. According to NAICS.

Source : Institut de la statistique du Québec.

Financial indicators

	2008	2009
Average exchange rate (C\$/US\$)	1.066	1.142
Average exchange rate (C\$/€)	1.962	1.780
Average exchange rate (C\$/¥)	1.560	1.586
Average exchange rate (C\$/¥)	0.010	0.012
Average discount rate		
• Canada (%)	3.21	0.65
• United States (%)	1.84	0.16
Average prime rate		
• Canada (%)	4.73	2.40
• United States (%)	4.88	3.25
Stock market index (paper and forest product market prices, Toronto Exchange)	8,987.70	11,746.11

Source : Bank du Canada and <http://www.djindexes.com>.

12 The forest sector in Québec's economy

Highlights (cont'd)

12.00.01 (2)

Average price of principal forest products

	2008	2009
Softwood lumber, Toronto green (composite price) (C\$/1,000 bd ft)	248.3	230.2
Softwood lumber, Columbus dry (composite price) (C\$/1,000 bd ft)	300.3	289.7
Hardwood lumber, Montreal exchange (weighted price) (C\$/1,000 bd ft)	563.6	508.2
Plywood (12.5 mm) (C\$/1,000 sq.ft.)	433.0	..
Oriented strand board (OSB) 7/16" (C\$/1,000 sq.ft.)	190.0	206.0
Bleached softwood kraft pulp (US\$/mt)	740.0	830.0
Bleached hardwood kraft pulp (US\$/mt)	665.0	715.0
Newsprint (US\$/mt)	530.0	580.0

Sources : Pribec, Madison's Canadian Lumber Reporter, Random Lengths Publications, RISI, Inc.

Estimated revenue from wood chips in Québec

(C\$/1 000 bd ft) ¹

	2008	2009
	129.0	125.0

1. Estimated revenue for every 1,000 bd ft produced.

Source : Ministère des Ressources naturelles et de la Faune (internal compilation).

Profits made by Canada's forest products industry

	2007	2008
Profits (\$, million)	247	-6
Profits/sales (%)	1.2	-0.1

Source : Statistics Canada : 61-008.

Share of paper mill-integrated sawmills in authorized roundwood consumption

1987	28.1 % of total consumption
2008	46.8 % of total consumption

Source : Ministère des Ressources naturelles et de la Faune (internal compilation).

Budget allocated to the secteur des forêts and the secteur des services régionaux, MRNF ¹, 2008-2009 ² (\$, 000s)

Research and development	9,921.0
Forestry policies and programs	166,579.8
Forest management planning and monitoring	64,200.0
Seedling production	39,842.1
Internal management and support	900.0
Forestry loans	500.0
Total	281,942.9

1. Ministère des Ressources naturelles et de la Faune.

2. Including Forestry Fund (financed jointly by the MRNF and the industry) :
forestry research, forest surveys, seedling production, planning and control.

Source : Ministère des Ressources naturelles et de la Faune, Direction des ressources financières (internal compilation).

12 The forest sector in Québec's economy

Economic and financial indicators

Economic indicators for the forest sector

Québec's balance of trade ¹ in the forest products sector and for all products ²
(\$, million)

12.01.13

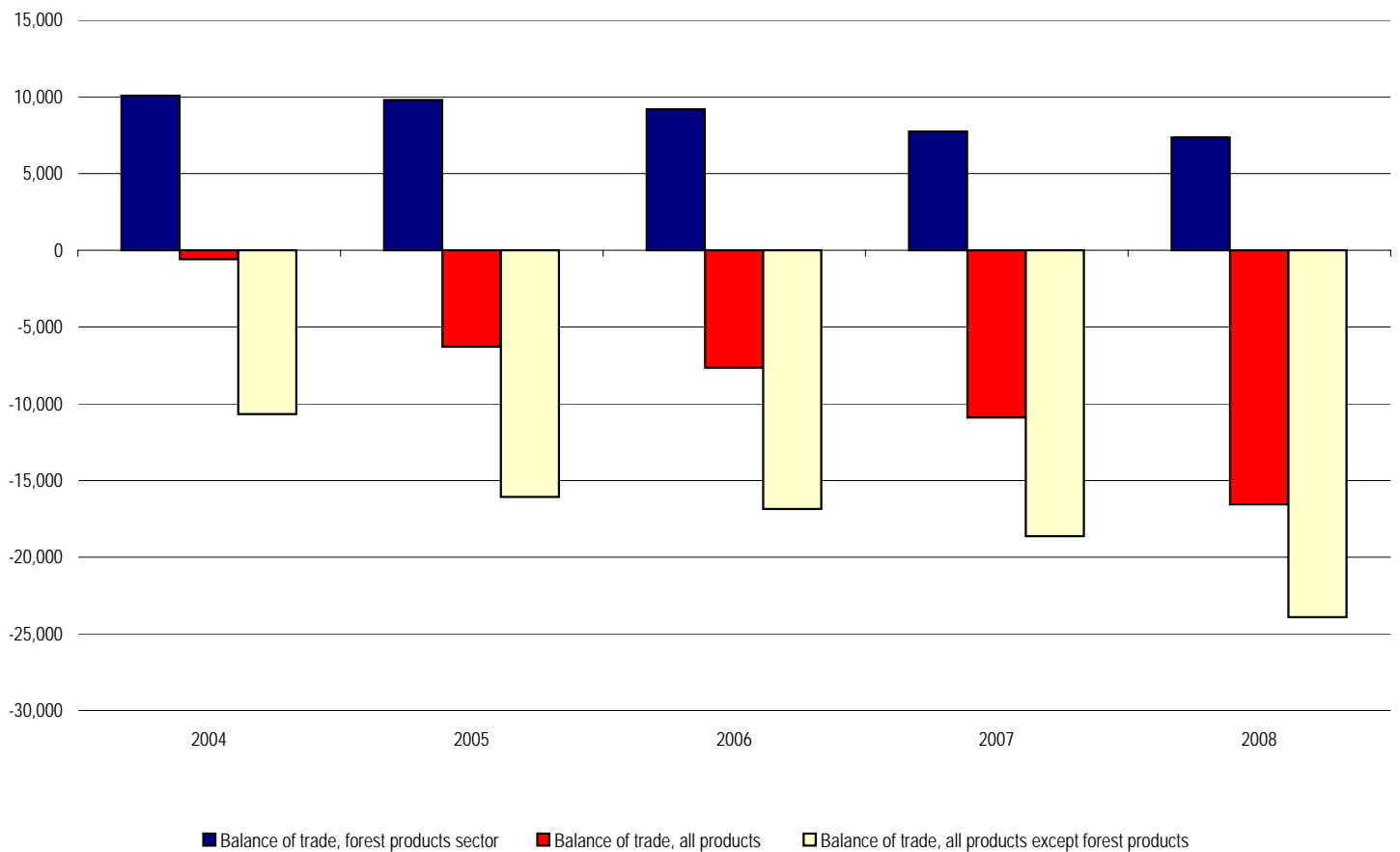

1. Balance of trade of commercial goods with international destinations.

2. According to the North American Industry Classification System (NAICS)

Source : Institut de la statistique du Québec.

12 The forest sector in Québec's economy

Economic and financial indicators (cont'd)

Economic indicators for the forest sector (cont'd)

Québec's balance of trade ¹ in the forest products sector (including furniture and printing) and for all products ² (\$, million)

12.01.13 (2)

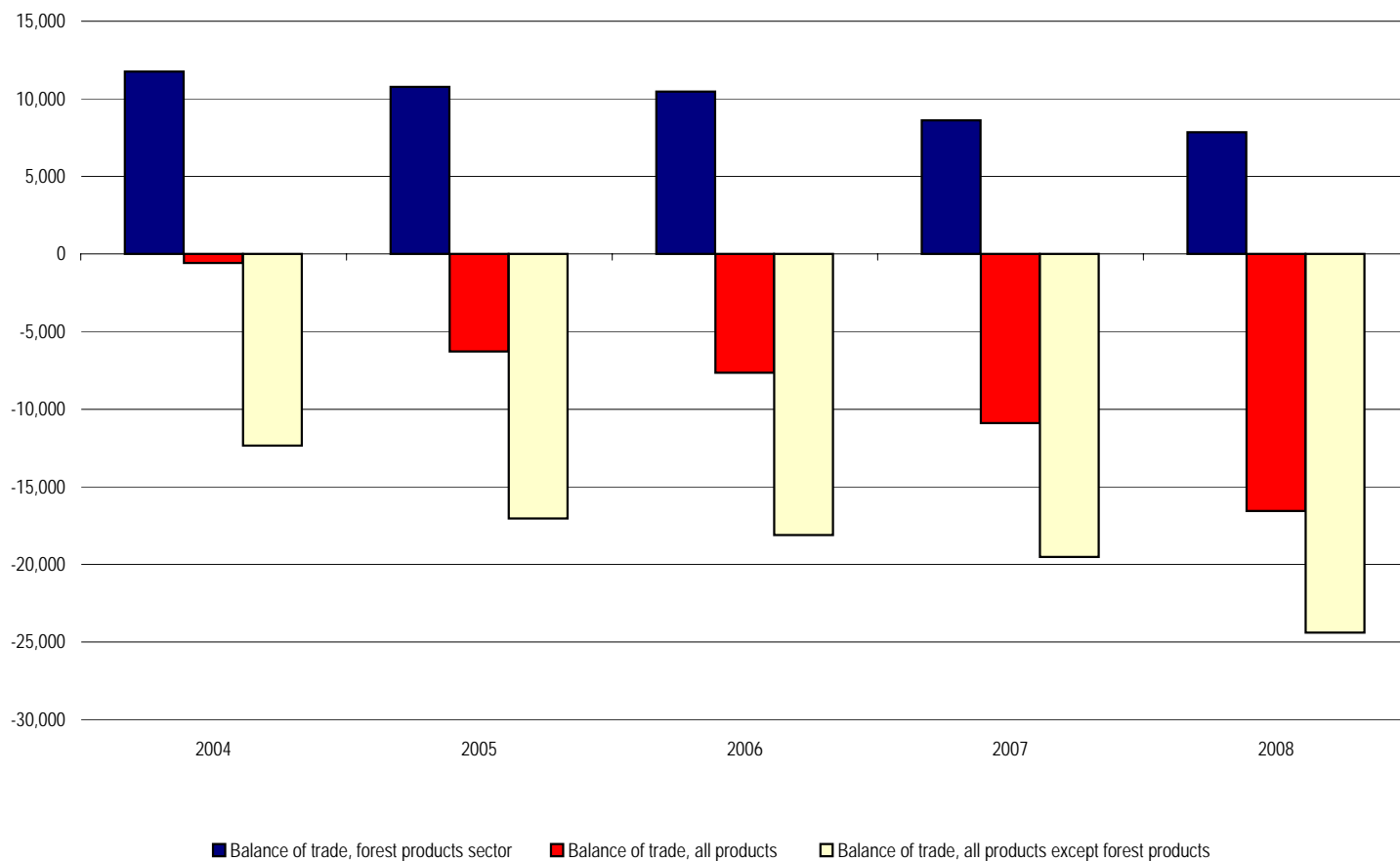

1. Balance of trade of commercial goods with international destinations.

2. According to the North American Industry Classification System (NAICS)

Source : Institut de la statistique du Québec.

12 The forest sector in Québec's economy

Economic and financial indicators (cont'd)

Economic indicators for the forest sector (cont'd)

Price trends

1) Softwood lumber (composit price)

(\$/1,000 bd ft)

12.01.38

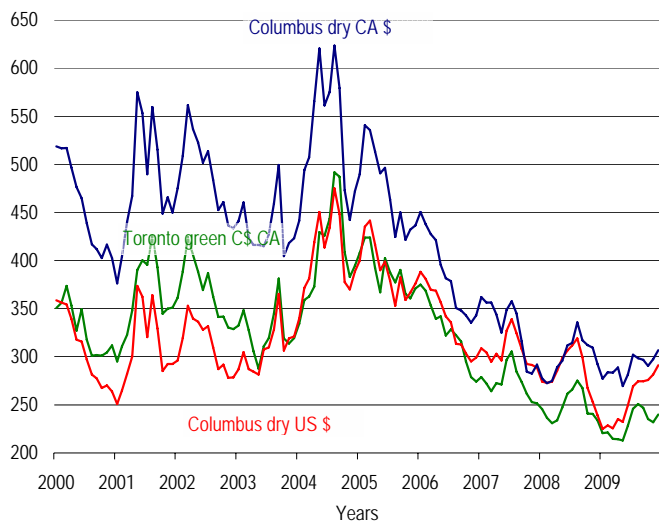

Source : Pribec.

2) Hardwood lumber (weighted price) ¹

(C\$/1,000 bd ft)

12.01.39

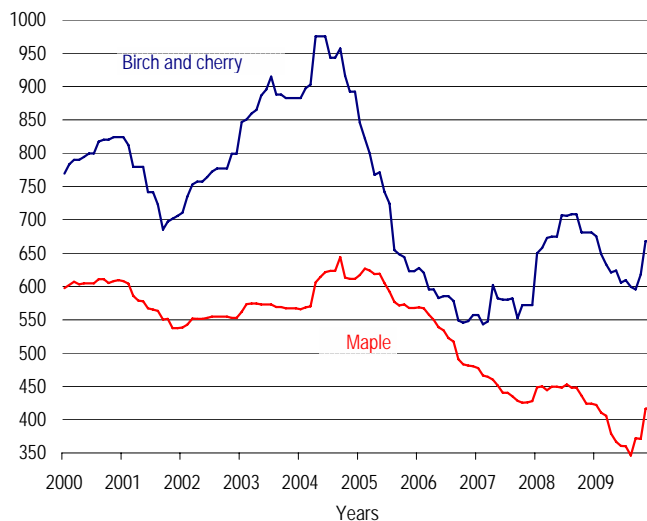

1. 4/4 raw, F.O.B. mill.

Source : Pribec.

3) Plywood (12.5 mm)

(C\$/1,000 sq.ft.)

12.01.40

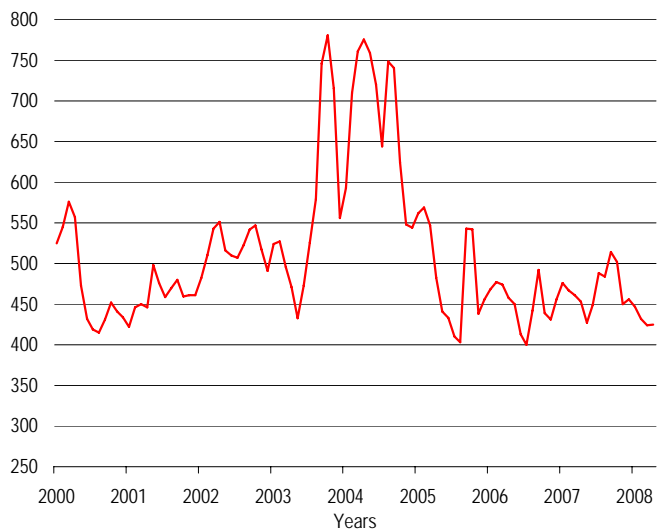

Source : Madison's Canadian Lumber Reporter.

4) Board

(\$/1,000 sq.ft.)

12.01.41

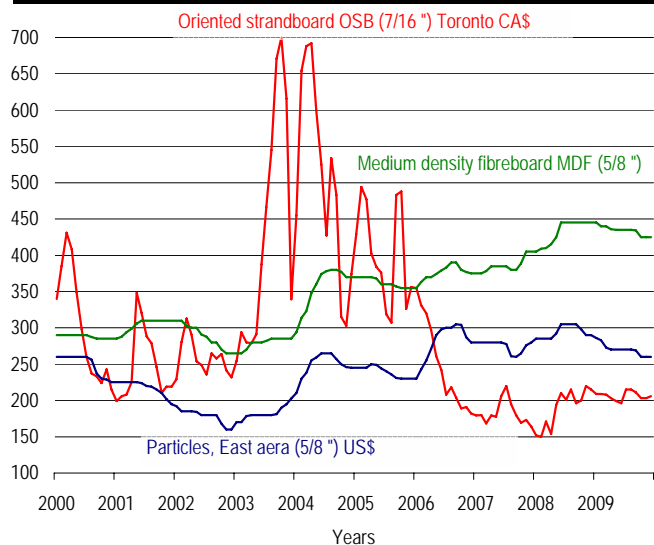

Source : Random Lengths.

12 The forest sector in Québec's economy

Economic and financial indicators (cont'd)

Economic indicators for the forest sector (cont'd)

Price trends (cont'd)

5) Market pulp

(US\$/mt)

12.01.42

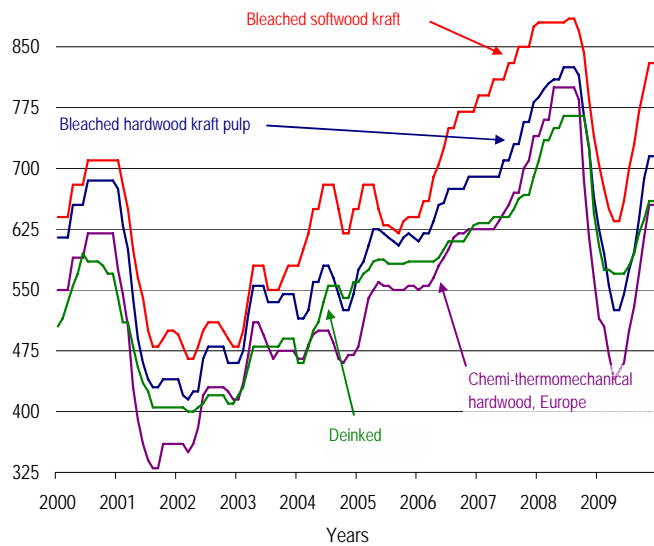

Source : RISI, Inc.

6) Paper

(US\$)

12.01.43

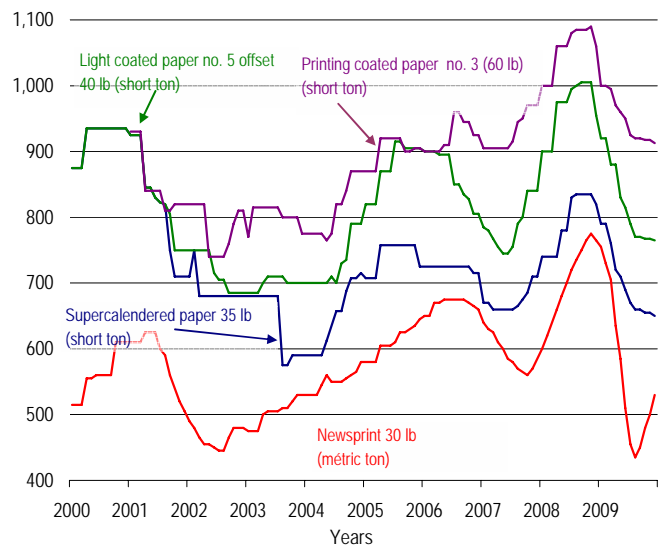

Source : RISI, Inc.

7) Revenue from Chips ¹

(C\$/1,000 bd ft)

12.01.44

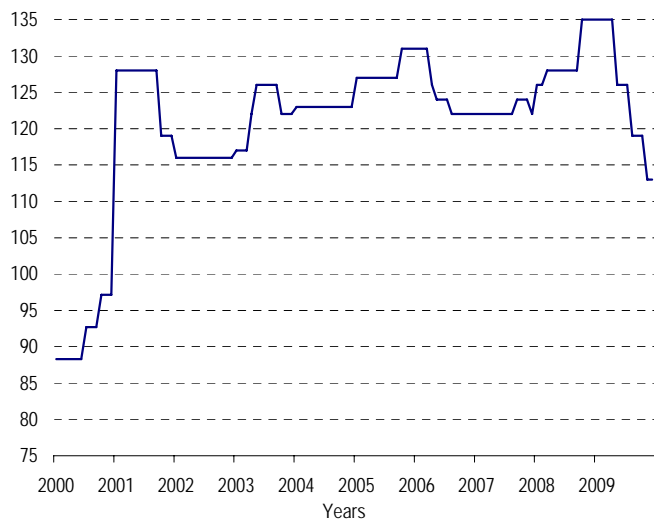

1. The calculation takes into account chip production per 1,000 bd ft.

Source : Ministère des Ressources naturelles et de la Faune (internal compilation).

12 The forest sector in Québec's economy

Economic and financial indicators (cont'd)

Financial indicators for the forest sector (cont'd)

Wood and paper (Canada)

Quarterly profits (\$, million) and profits before extraordinary items/sales (%)

12.01.45

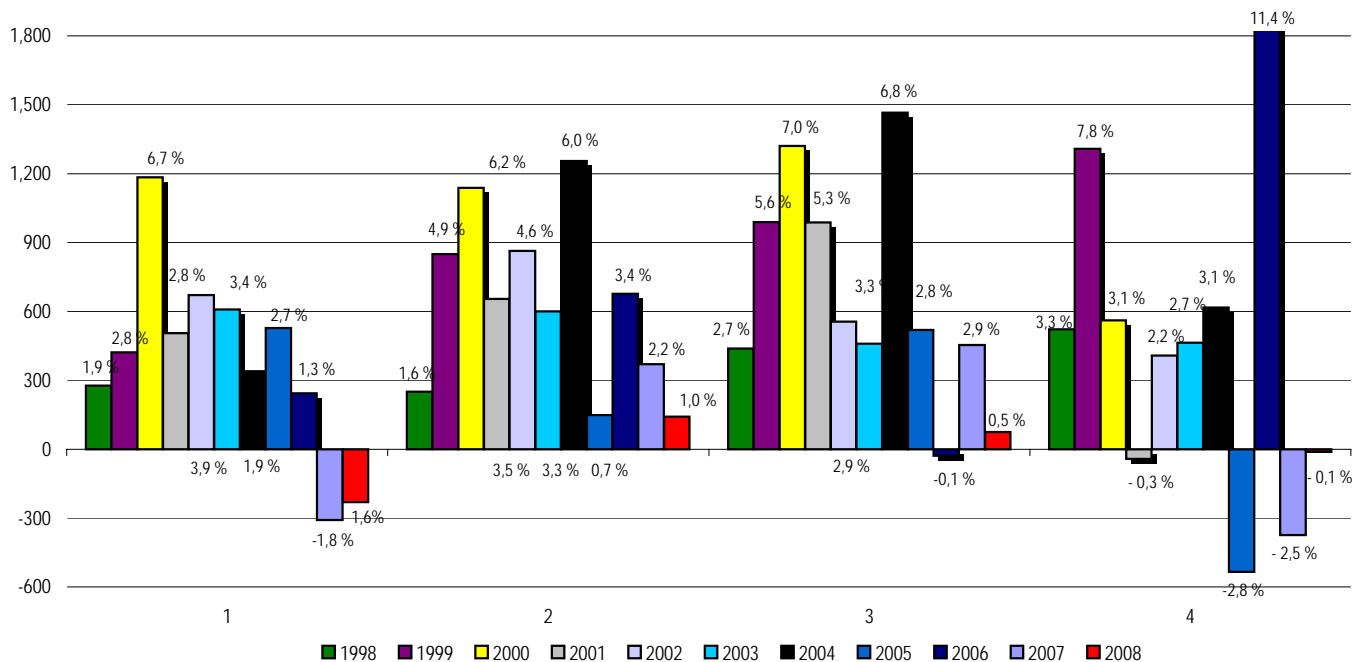

Source : Statistique Canada : 61-008.

12 The forest sector in Québec's economy

Economic and financial indicators (cont'd)

Economic indicators for the forest sector (cont'd)

Share of paper mill-integrated sawmills in Québec's authorized roundwood consumption (%)

12.01.47

March 1987

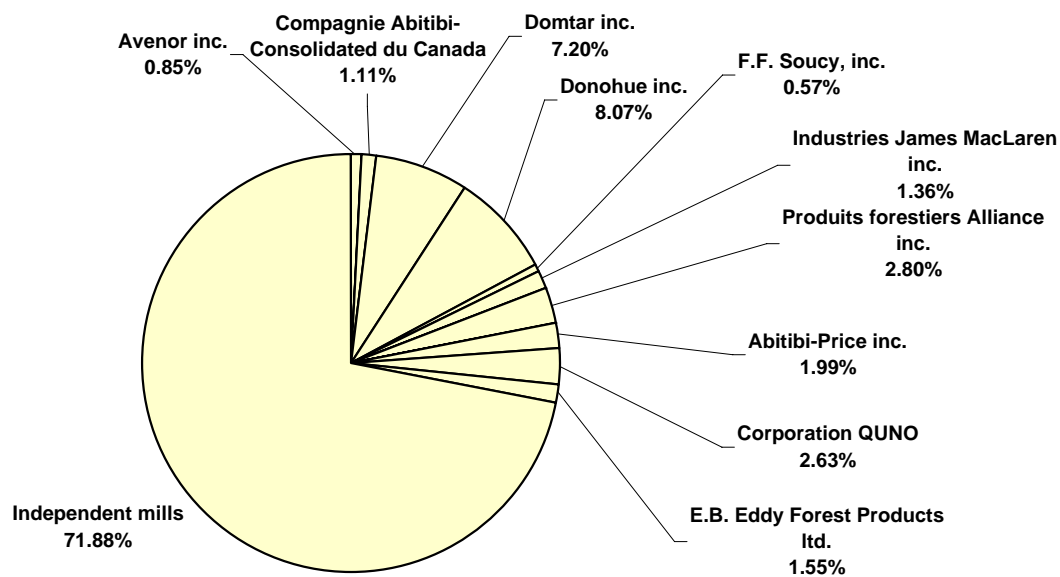

12.01.48

Décember 2008

